

# NEXOIL

**FLUID SYSTEMS MANUFACTURING**

MICROPUMP AIR/OIL

USE AND MAINTENANCE MANUAL

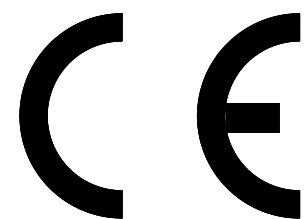

Edition July 2015

## Index

<b>GENERAL</b> .....	<b>3</b>
<b>TECHNICAL CHARACTERISTIC</b> .....	<b>3</b>
MINIMUM LEVEL SENSOR .....	3
ELECTROVALVE .....	3
<b>TYPES</b> .....	<b>4</b>
VERSION WITH BOX AND TANK 1.5LT .....	4
<i>FIXING AND DIMENSIONS</i> .....	4
<i>VERSION WITH TWO ELECTROVALVES AND COAXIAL AIR/OIL HOSES (7018106–7018111)</i> .....	5
<i>VERSION WITH TWO ELECTROVALVES AND SEPARATE AIR/OIL HOSES (7018130–7018135)</i> .....	5
<i>PNEUMATIC FREQUENCY GENERATOR AND COAXIAL AIR/OIL HOSES (7018100–7018105)</i> .....	6
<i>PNEUMATIC FREQUENCY GENERATOR AND SEPARATE AIR/OIL HOSES (7018124–7018129)</i> .....	6
VERSION WITH BOX AND TANK 3LT .....	8
<i>VERSION WITH PNEUMATIC FREQUENCY GENERATOR AND COAXIAL HOSES (7018112 – 7018117)</i> .....	9
<i>VERSION WITH PNEUMATIC FREQUENCY GENERATOR AND SEPARATE HOSES (7018136 – 7018141)</i> .....	9
<i>VERSION WITH TWO ELECTROVALVE AND COAXIAL HOSES (7018118 – 7018123)</i> .....	10
<i>VERSION WITH TWO ELECTROVALVE AND SEPARATE HOSES (7018142 – 7018147)</i> .....	10
<i>TAB. OF VERSIONS WITH BOX AND TANK 3lt</i> .....	11
VERSION WITHOUT BOX AND TANK 3 LT. ....	12
<i>VERSION WITH PNEUMATIC FREQUENCY GENERATOR AND COAXIAL HOSES (7018162–7018167)</i> .....	12
<i>ELETTROVALVE AND COAXIAL HOSES (7018174–7018179)</i> .....	13
<i>ELETTROVALVE AND SEPARATE HOSES (7018180–7018185)</i> .....	13
<i>TAB. OF VERSIONS WITHOUT BOX AND TANK 3lt</i> .....	14
<b>MICROPUMPS</b> .....	<b>15</b>
PNEUMATIC FREQUENCY GENERATOR – COAXIAL AIR-OIL HOSES (7018010-7018015) .....	15
PNEUMATIC FREQUENCY GENERATOR – SEPARATE AIR-OIL HOSES (7018018-7018023) .....	16
ELETTROVALVE – COAXIAL AIR-OIL HOSES (7018024-7018029) .....	16
ELETTROVALVE – SEPARATE AIR-OIL HOSES (7018030-7018035) .....	17
ASSEMBLY KIT ELETTROVALVE (7115008) .....	17
<b>NOZZLE</b> .....	<b>19</b>
NOZZLE WITH FLEXIBLE PIPE FOR AIR-OIL COAXIAL HOSE WITH MAGNET (7304002) .....	19
NOZZLE FOR CUTTING BLADE WITH 2 INLETS AND 5 OUTLETS (7307003) .....	19
NOZZLE FOR CUTTING BLADE WITH 1 INLETS AND 3 OUTLETS (7307004) .....	20
<i>ASSEMBLY INSTRUCTION FOR CUTTING BLADE NOZZLE</i> .....	20
<b>UNPACKING AND INSTALLATION</b> .....	<b>21</b>
HYDRAULIC CONNECTIONS .....	21
PNEUMATIC CONNECTIONS .....	21
CONNECT THE MAIN AIR SUPPLY HOSE TO THE QUICK ENTRY AS REQUIRED BY THE VERSION OF INSTALLED EQUIPMENT. ....	21
ELECTRIC CONNECTIONS .....	21
<b>INSTRUCTIONS</b> .....	<b>21</b>
START OF THE SYSTEM .....	21
SET LUBRICANT DELIVERY .....	22
FREQUENCY GENERATOR SET .....	23
SETTING AIR FLOW .....	23
<b>MAINTENANCE</b> .....	<b>24</b>
<b>DI SPOSAL</b> .....	<b>24</b>
<b>TRANSPORT AND MOVEMENT</b> .....	<b>25</b>
<b>PRECAUTIONS</b> .....	<b>25</b>
ELECTRICITY .....	25
FLAMMABILITY .....	25
PRESSURE .....	25
CHARACTERISTIC AIR .....	25
<b>CONTRAINdicATIONS OF USE</b> .....	<b>26</b>
<b>RECOMMENDED SPARE PARTS</b> .....	<b>26</b>
KIT PRIMARY E.VALVE COD.7115003 .....	27
KIT SECONDARY E.VALVE COD.7115008 .....	27
KIT PRESSURE REGULATORE COD. 7115004 .....	27

## GENERAL

The Micropump AIR/OIL system is designed for applications on spindle, tools and chains.

The system is designed to have high performances at low cost.

## TECHNICAL CHARACTERISTIC

Air pressure	5 ÷ 8 bar
Working Temperature	-5 ÷ 55°C
Usable Lubricants	Mineral / synthetic
Oil viscosity at working temperature	32 ÷ 320 cSt
Protection grade with box	IP 55
Protection grade without box	IP 44
Pump ratio	28:1
Pneumatic timer	1 ÷ 66 cicli/minuto a 6 BAR

### *MINIMUM LEVEL SENSOR*

Temperature	80° max
Max power	40 W
Max current	2.5 A
Max power supply	50 V

### *ELECTROVALVE*

Technical data	3/2 NC 24V DC
----------------	---------------

## TYPES

*VERSION WITH BOX AND TANK 1.5lt*

FIXING AND DIMENSIONS

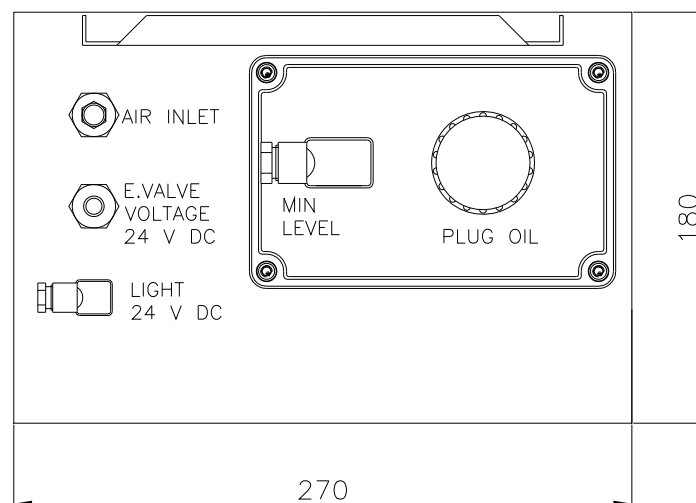
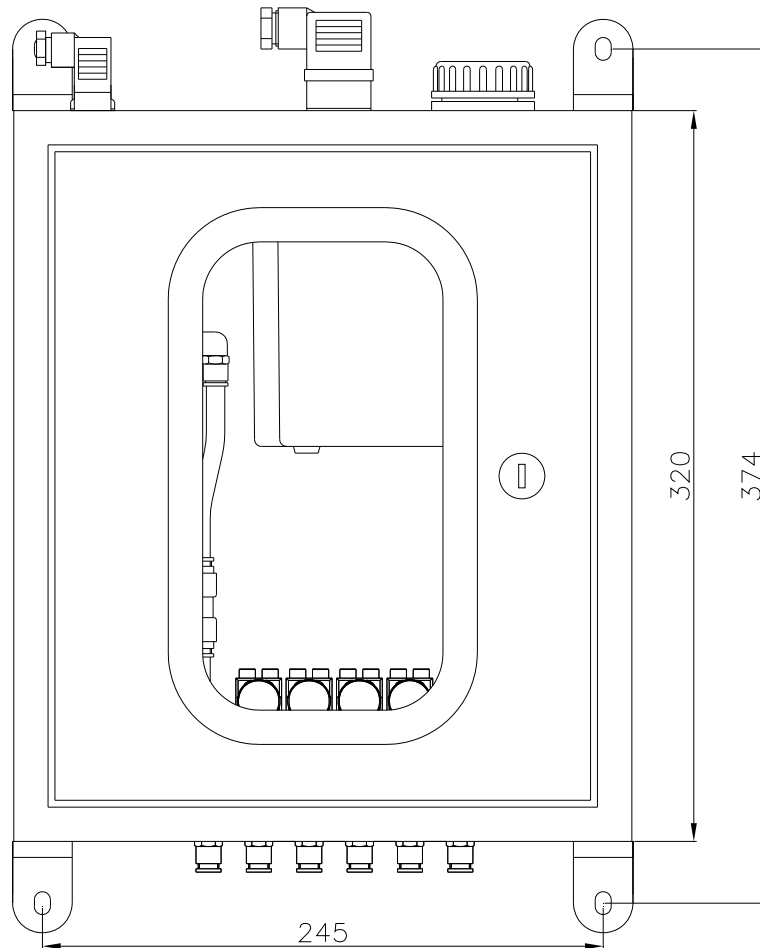

**VERSION WITH TWO ELECTROVALVES AND COAXIAL AIR/OIL HOSES (7018106-7018111)**

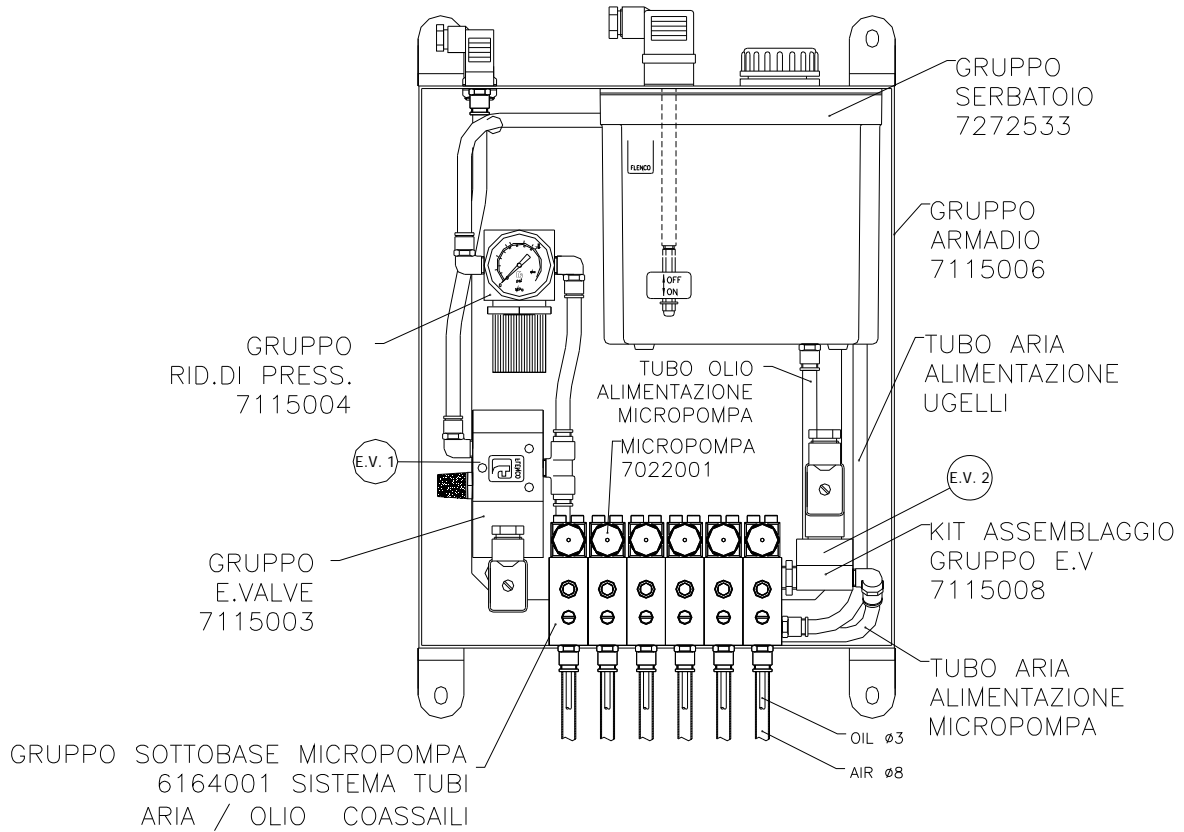

**VERSION WITH TWO ELECTROVALVES AND SEPARATE AIR/OIL HOSES (7018130-7018135)**

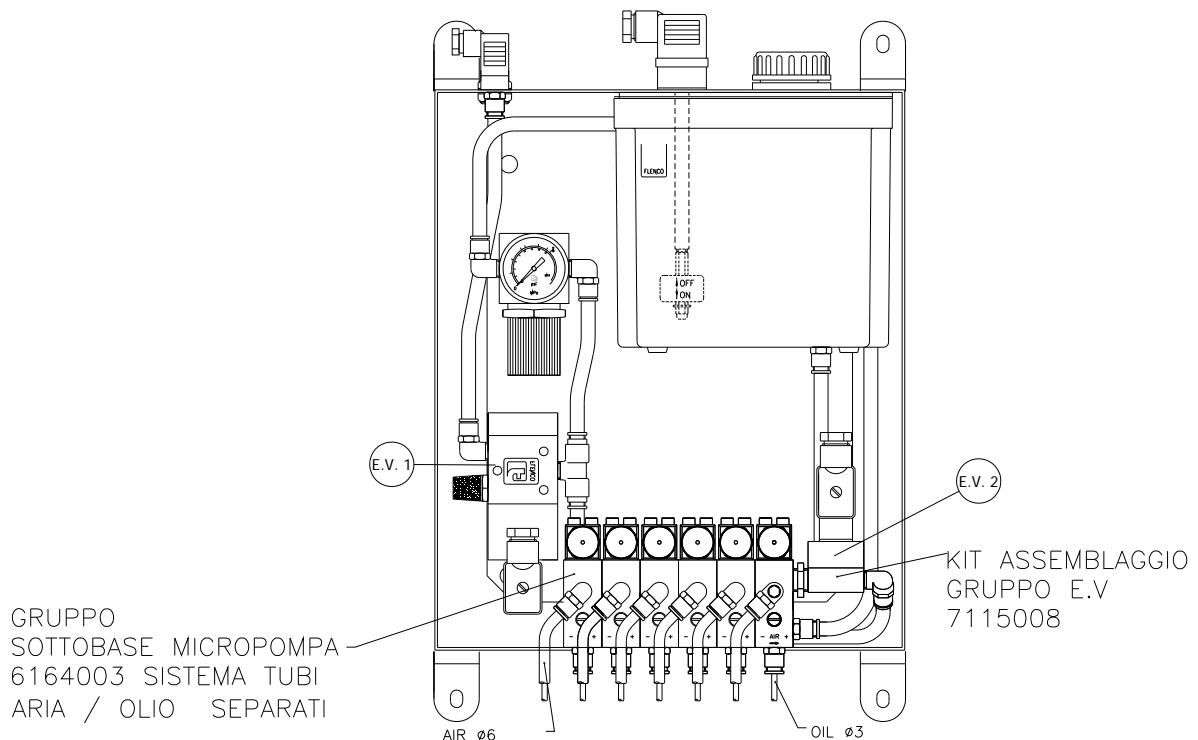

**PNEUMATIC FREQUENCY GENERATOR AND COAXIAL AIR/OIL HOSES (7018100–7018105)**

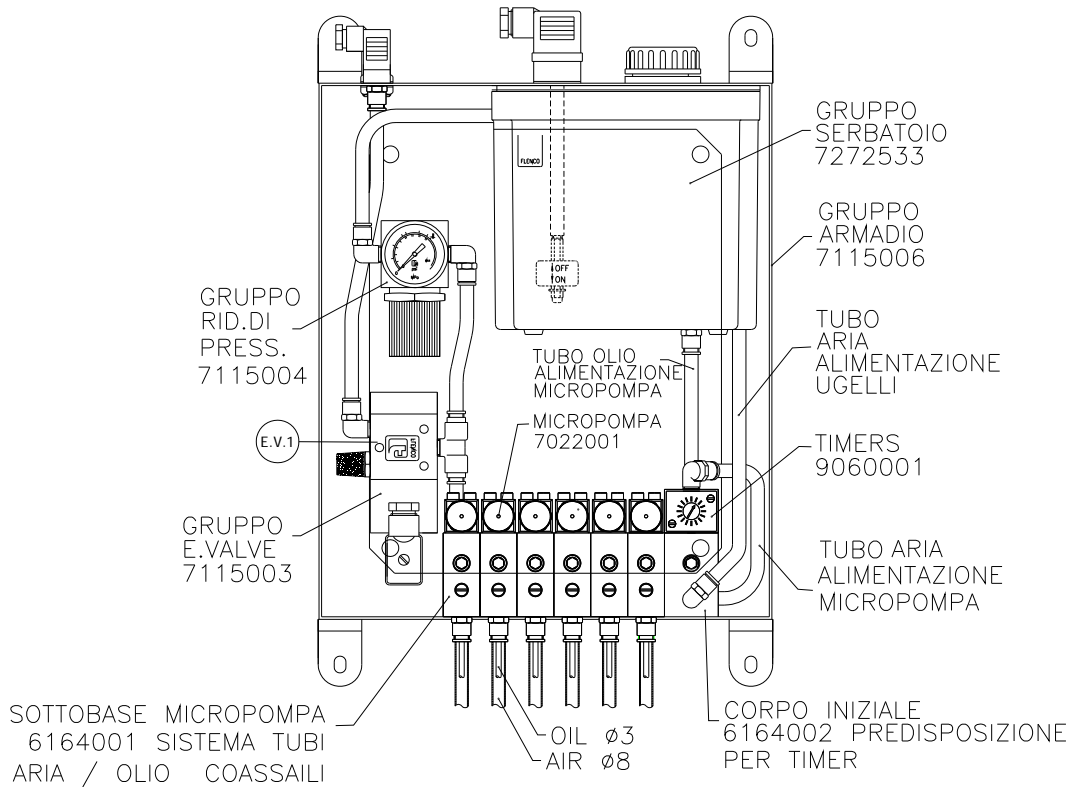

**PNEUMATIC FREQUENCY GENERATOR AND SEPARATE AIR/OIL HOSES (7018124–7018129)**

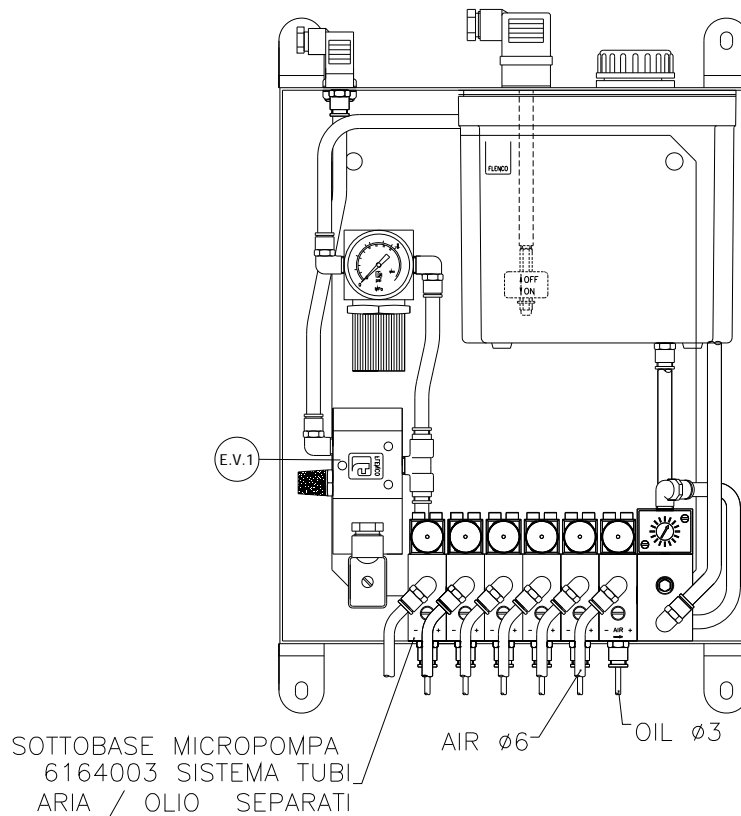

TAB. OF VERSIONS WITH BOX AND TANK 1.5lt

CODE	CHARACTERISTIC					
	NUMBER OF MICROPUMPS	PNEUMATIC FREQUENCY GENERATOR	E-VALVE	COAXIAL HOSES OUTLETS	SEPARATE HOSES OUTLETS	TANK
7018100	1	●		●		1.5 Lt
7018101	2	●		●		1.5 Lt
7018102	3	●		●		1.5 Lt
7018103	4	●		●		1.5 Lt
7018104	5	●		●		1.5 Lt
7018105	6	●		●		1.5 Lt
7018106	1		●	●		1.5 Lt
7018107	2		●	●		1.5 Lt
7018108	3		●	●		1.5 Lt
7018109	4		●	●		1.5 Lt
7018110	5		●	●		1.5 Lt
7018111	6		●	●		1.5 Lt
7018124	1	●			●	1.5 Lt
7018125	2	●			●	1.5 Lt
7018126	3	●			●	1.5 Lt
7018127	4	●			●	1.5 Lt
7018128	5	●			●	1.5 Lt
7018129	6	●			●	1.5 Lt
7018130	1		●		●	1.5 Lt
7018131	2		●		●	1.5 Lt
7018132	3		●		●	1.5 Lt
7018133	4		●		●	1.5 Lt
7018134	5		●		●	1.5 Lt
7018135	6		●		●	1.5 Lt

*VERSION WITH BOX AND TANK 3lt*

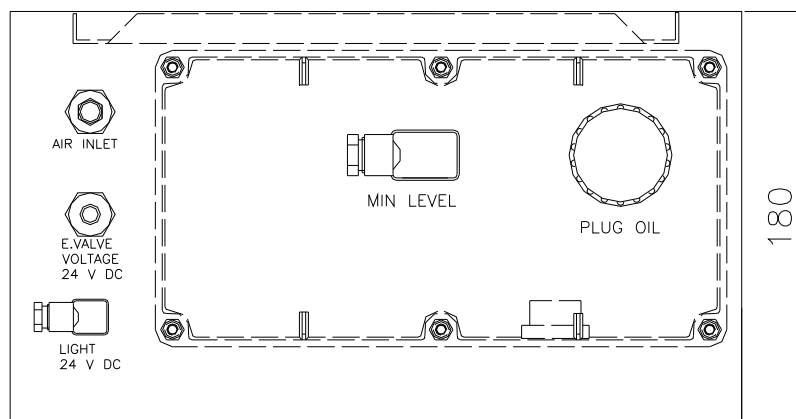
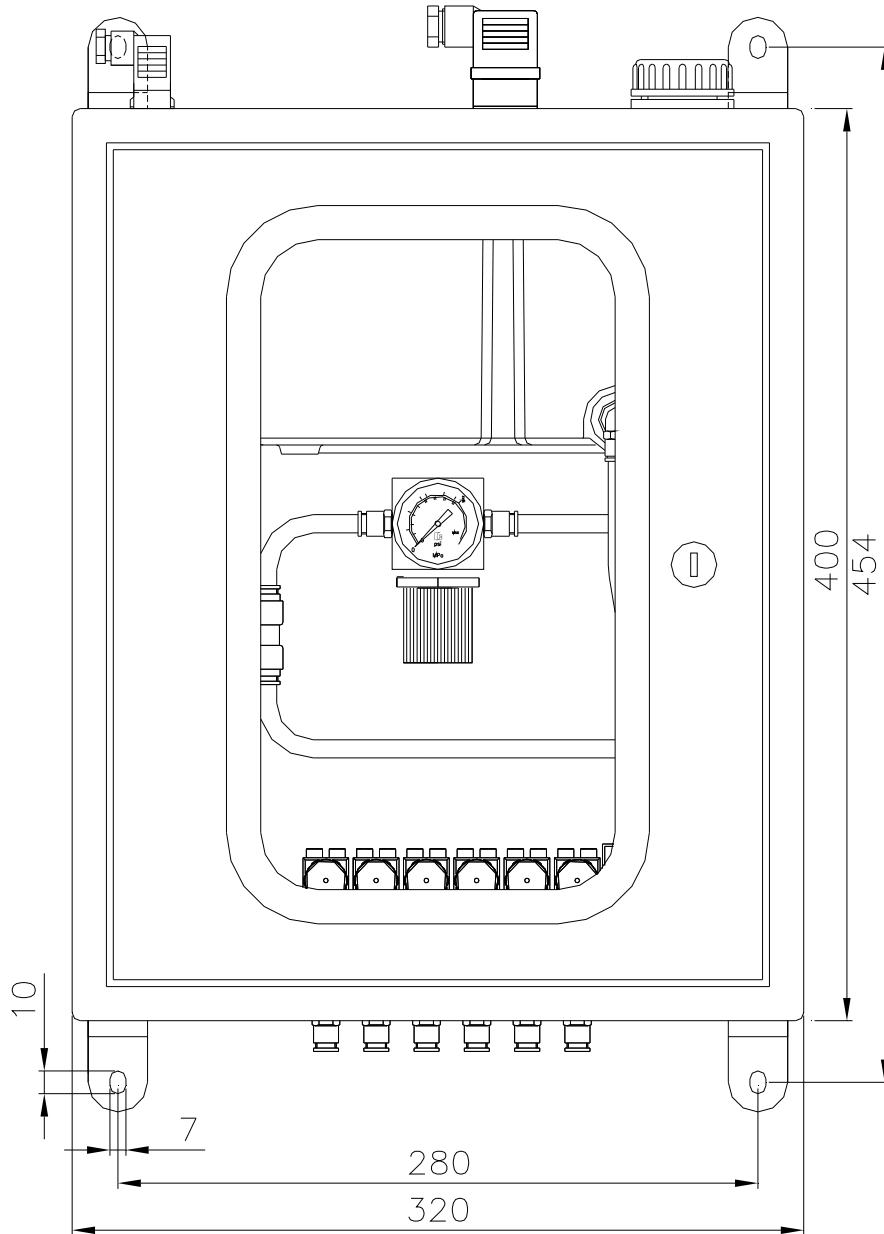



**VERSION WITH PNEUMATIC FREQUENCY GENERATOR AND COAXIAL HOSES  
(7018112 – 7018117)**

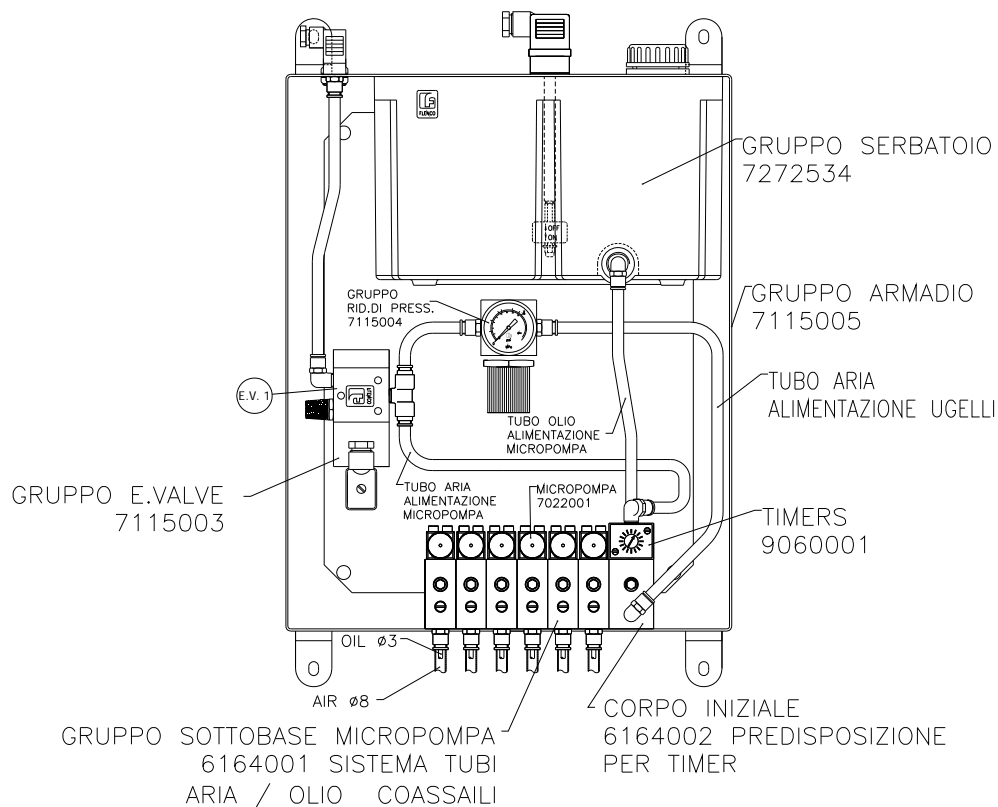

**VERSION WITH PNEUMATIC FREQUENCY GENERATOR AND SEPARATE HOSES  
(7018136 – 7018141)**

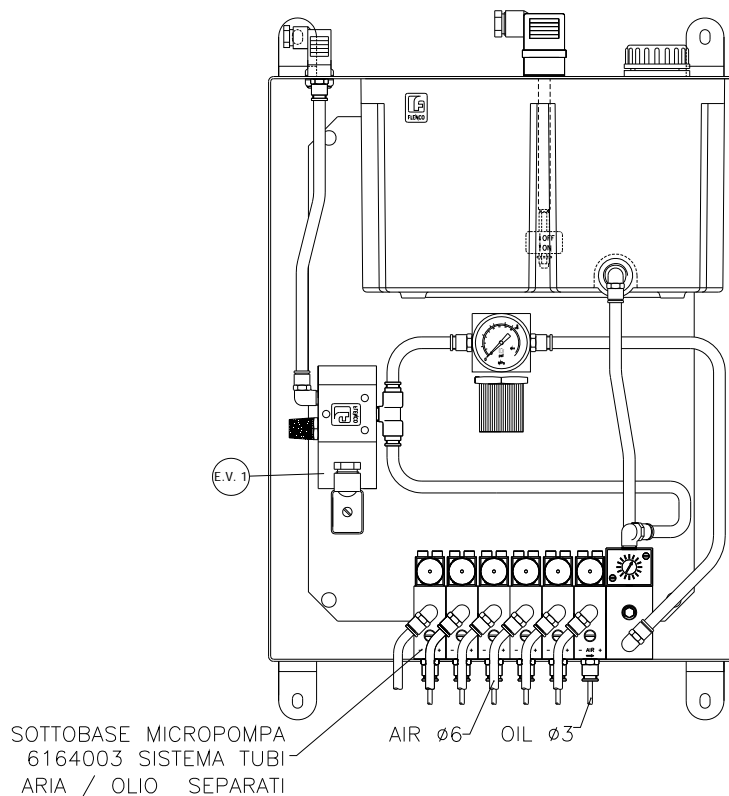

VERSION WITH TWO ELECTROVALVE AND COAXIAL HOSES  
(7018118 – 7018123)

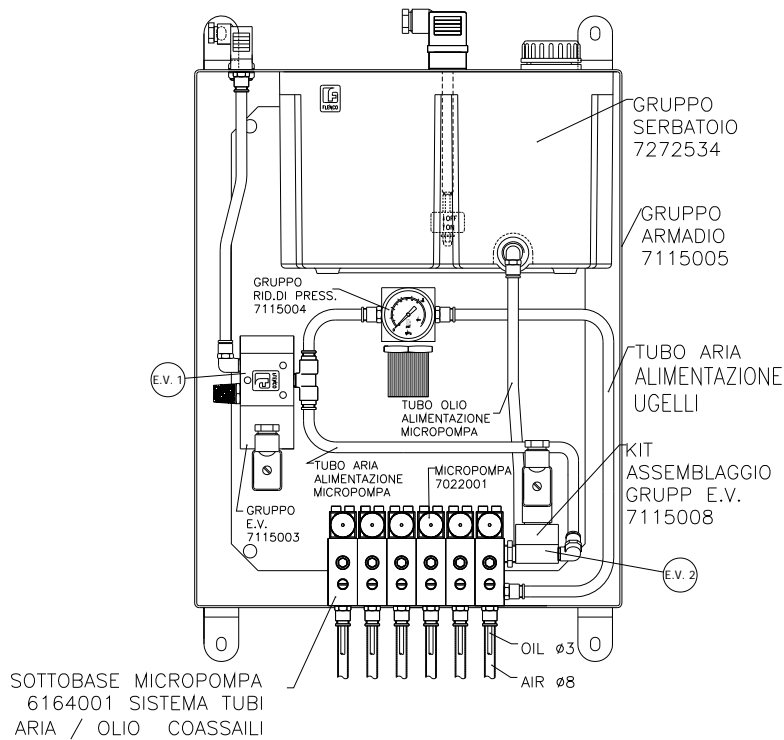

VERSION WITH TWO ELECTROVALVE AND SEPARATE HOSES  
(7018142 – 7018147)

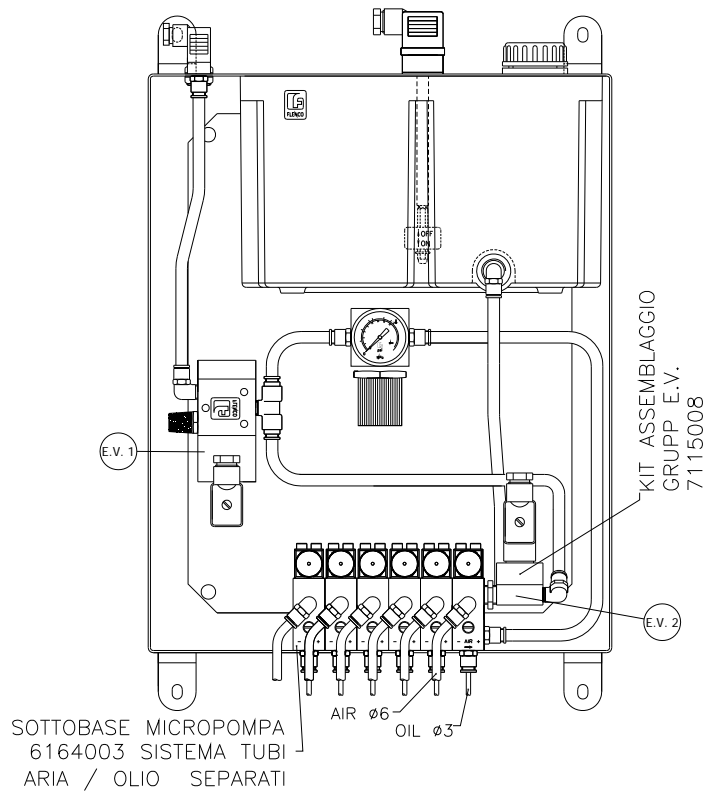

TAB. OF VERSIONS WITH BOX AND TANK 3lt

CODE	CHARACTERISTIC					
	NUMBER OF MICROPUMPS	PNEUMATIC FREQUENCY GENERATOR	E- VALVE	COAXIAL HOSES OUTLETS	SEPARATE HOSES OUTLETS	TANK
7018112	1	●		●		3 Lt
7018113	2	●		●		3 Lt
7018114	3	●		●		3 Lt
7018115	4	●		●		3 Lt
7018116	5	●		●		3 Lt
7018117	6	●		●		3 Lt
7018118	1		●	●		3 Lt
7018119	2		●	●		3 Lt
7018120	3		●	●		3 Lt
7018121	4		●	●		3 Lt
7018122	5		●	●		3 Lt
7018123	6		●	●		3 Lt
7018136	1				●	3 Lt
7018137	2				●	3 Lt
7018138	3				●	3 Lt
7018139	4				●	3 Lt
7018140	5				●	3 Lt
7018141	6				●	3 Lt
7018142	1		●		●	3 Lt
7018143	2		●		●	3 Lt
7018144	3		●		●	3 Lt
7018145	4		●		●	3 Lt
7018146	5		●		●	3 Lt
7018147	6		●		●	3 Lt

*VERSION WITHOUT BOX AND TANK 3 Lt.*

**VERSION WITH PNEUMATIC FREQUENCY GENERATOR AND COAXIAL HOSES  
(7018162–7018167)**

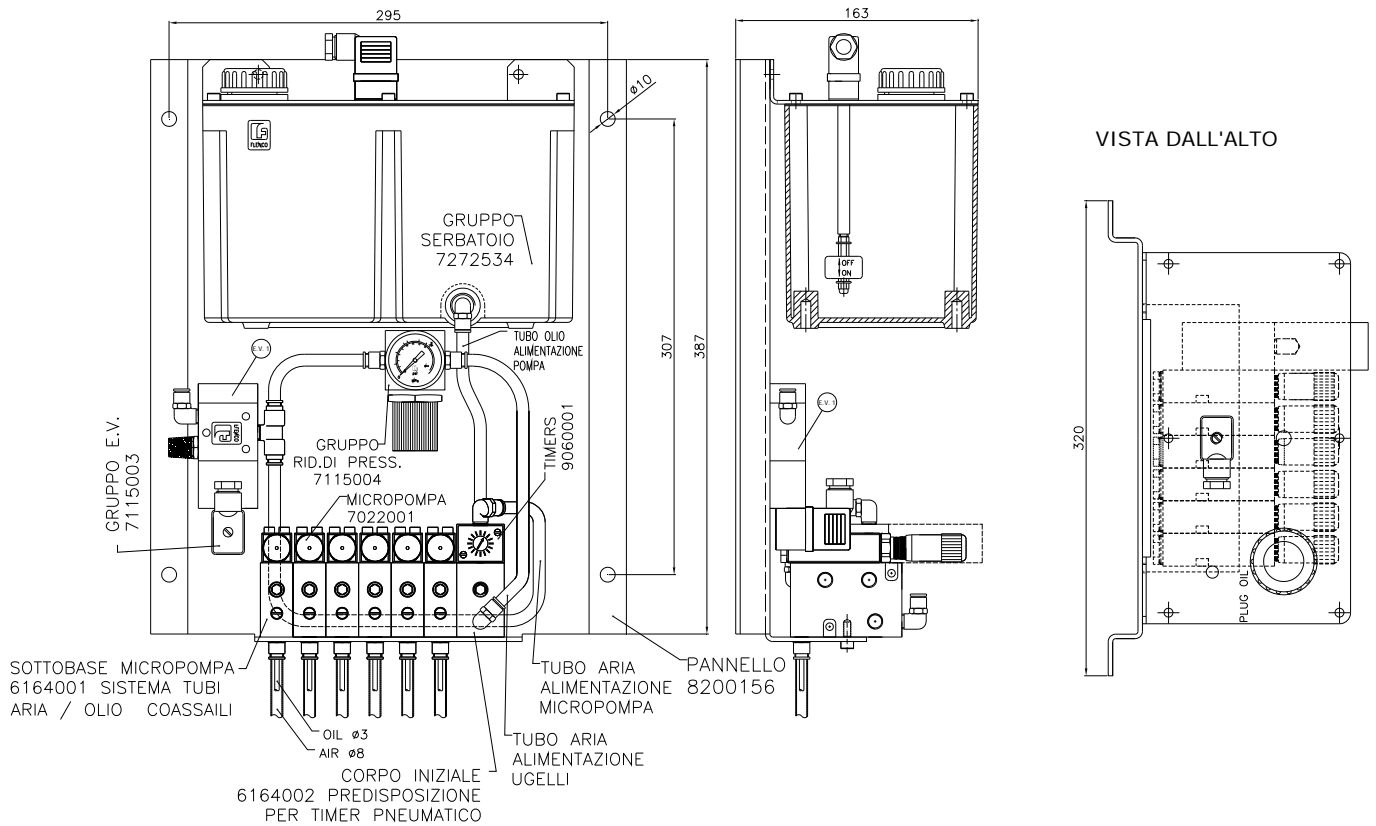

**VERSION WITH PNEUMATIC FREQUENCY GENERATOR AND SEPARATE HOSES  
(7018168–7018173)**

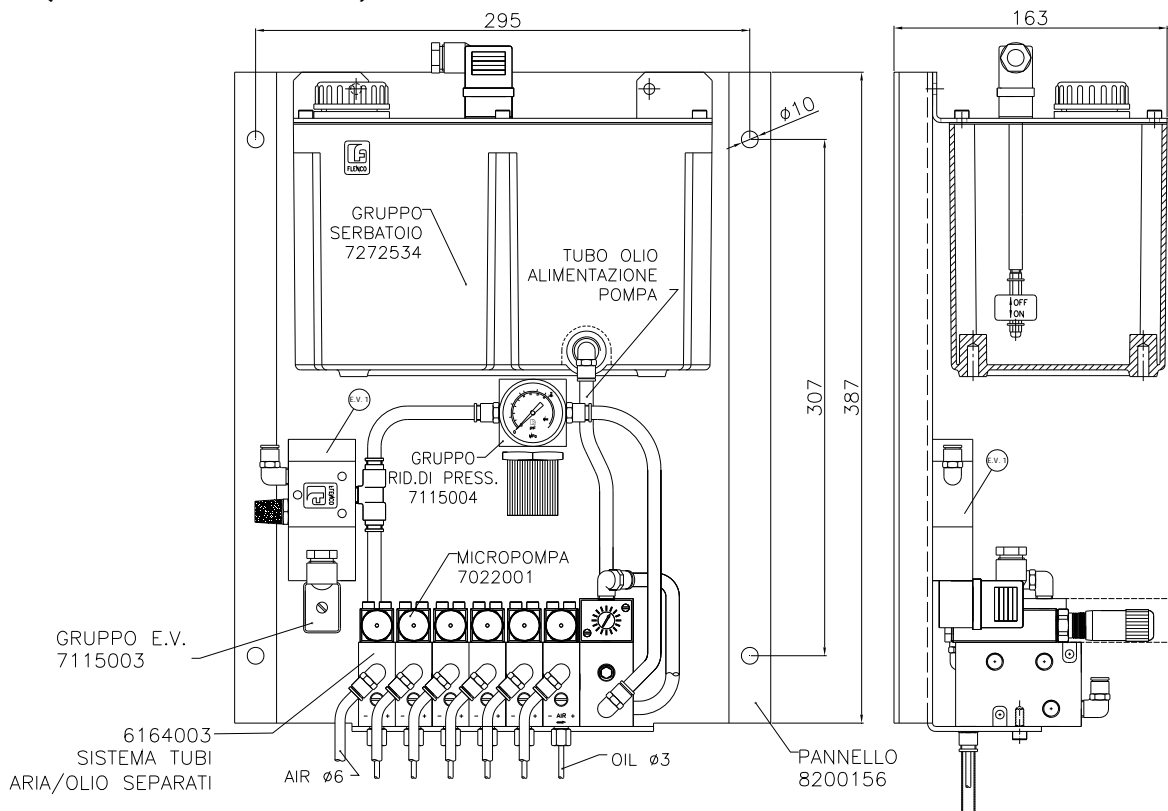

**ELETTROVALVE AND COAXIAL HOSES (7018174–7018179)**

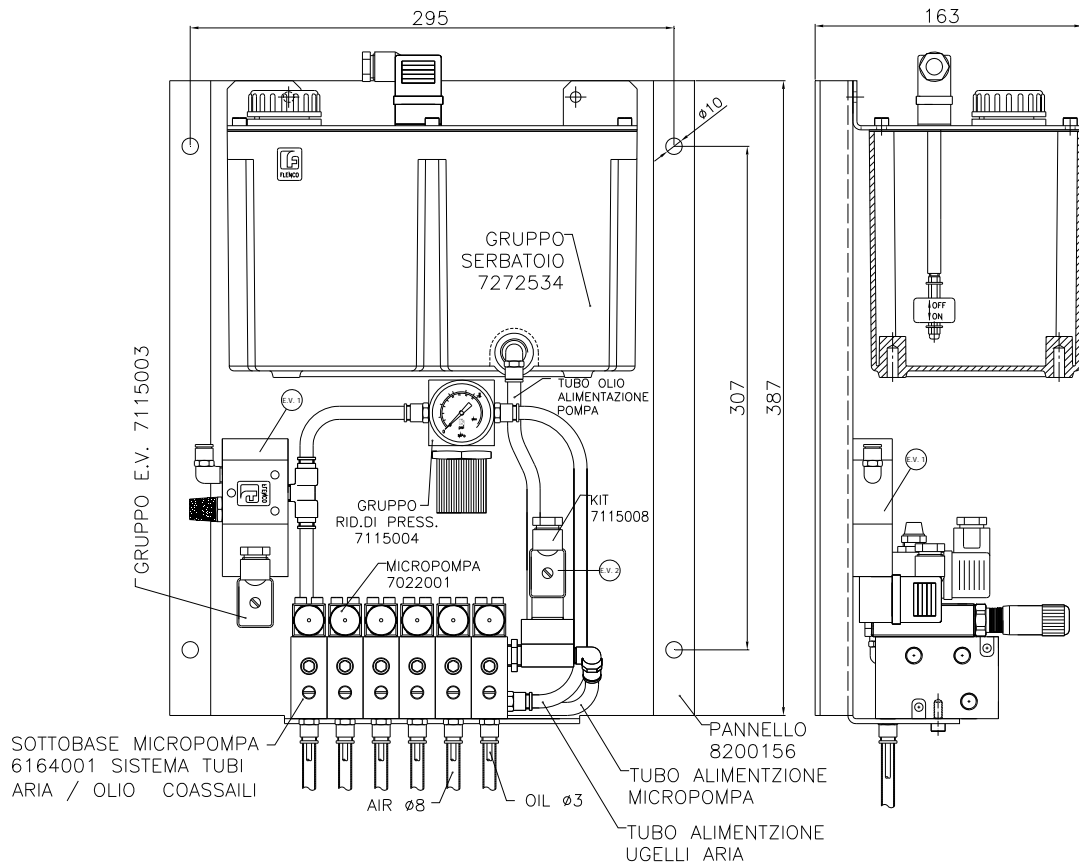

**ELETTROVALVE AND SEPARATE HOSES (7018180–7018185)**

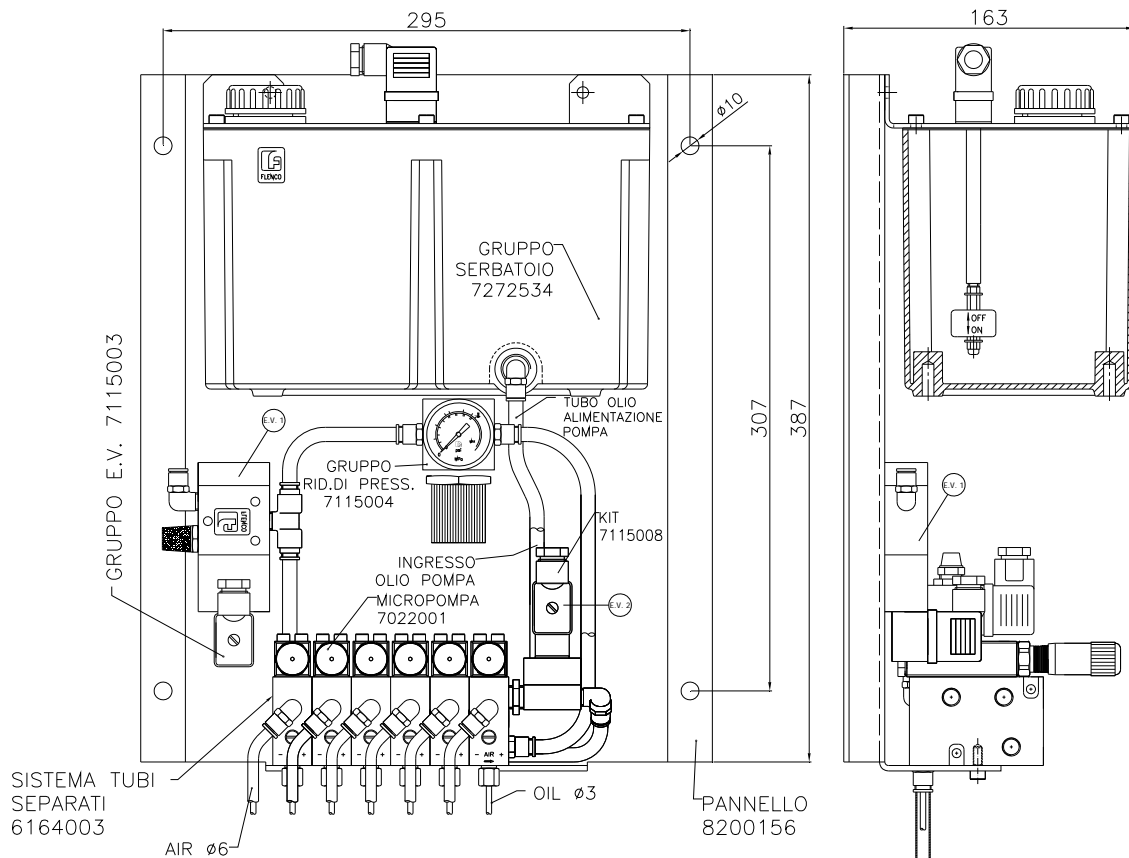

TAB. OF VERSIONS WITHOUT BOX AND TANK 3lt

CODE	CHARACTERISTIC					
	NUMBER OF MICROPUMPS	PNEUMATIC FREQUENCY GENERATOR	E-VALVE	COAXIAL HOSES OUTLETS	SEPARATE HOSES OUTLETS	TANK
7018162	1	●		●		3 Lt
7018163	2	●		●		3 Lt
7018164	3	●		●		3 Lt
7018165	4	●		●		3 Lt
7018166	5	●		●		3 Lt
7018167	6	●		●		3 Lt
7018174	1		●	●		3 Lt
7018175	2		●	●		3 Lt
7018176	3		●	●		3 Lt
7018177	4		●	●		3 Lt
7018178	5		●	●		3 Lt
7018179	6		●	●		3 Lt
7018168	1	●			●	3 Lt
7018169	2	●			●	3 Lt
7018170	3	●			●	3 Lt
7018171	4	●			●	3 Lt
7018172	5	●			●	3 Lt
7018173	6	●			●	3 Lt
7018180	1		●		●	3 Lt
7018181	2		●		●	3 Lt
7018182	3		●		●	3 Lt
7018183	4		●		●	3 Lt
7018184	5		●		●	3 Lt
7018185	6		●		●	3 Lt

# MICROPUMPS

## PNEUMATIC FREQUENCY GENERATOR – COAXIAL AIR-OIL HOSES (7018010-7018015)

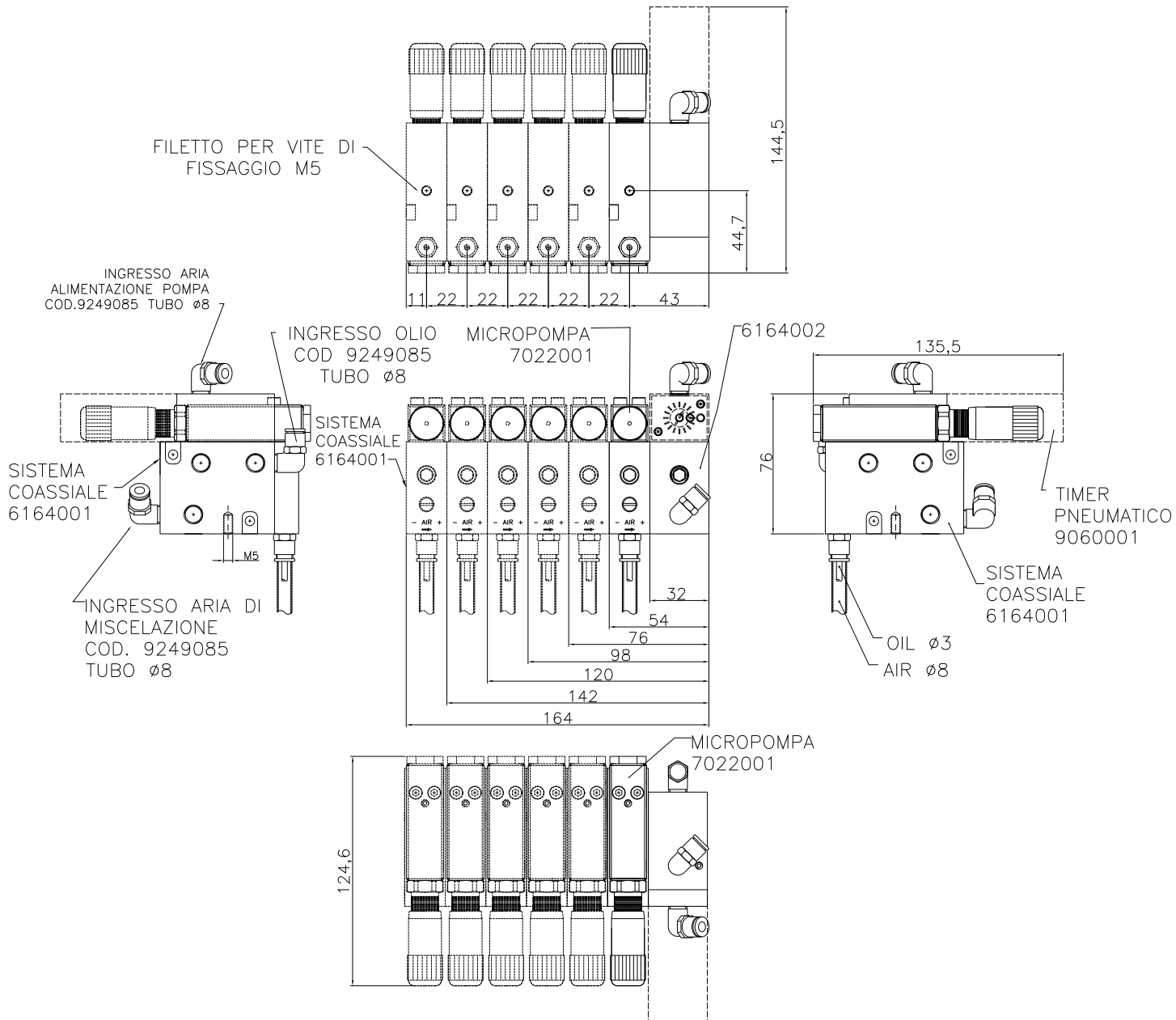

**PNEUMATIC FREQUENCY GENERATOR – SEPARATE AIR-OIL HOSES (7018018-7018023)**

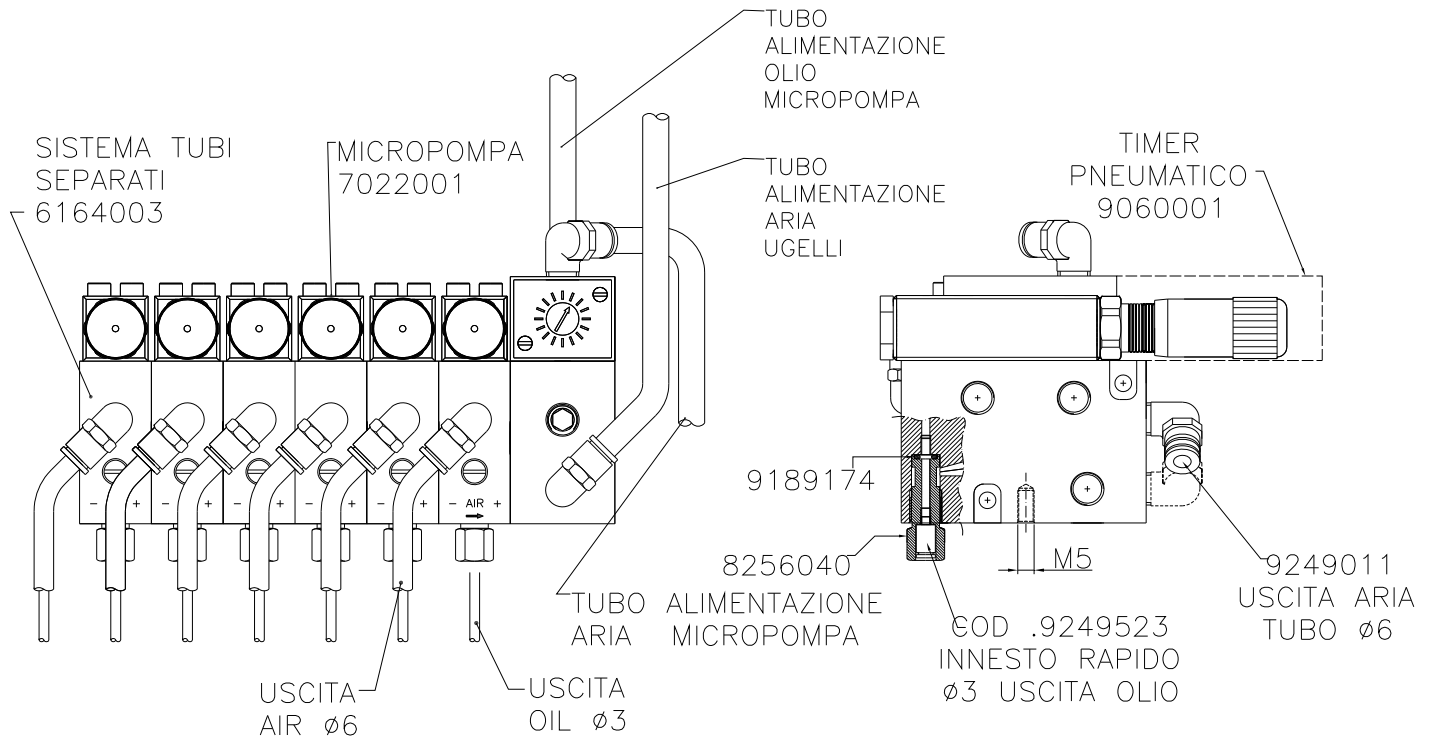

**ELETTROVALVE – COAXIAL AIR-OIL HOSES (7018024-7018029)**

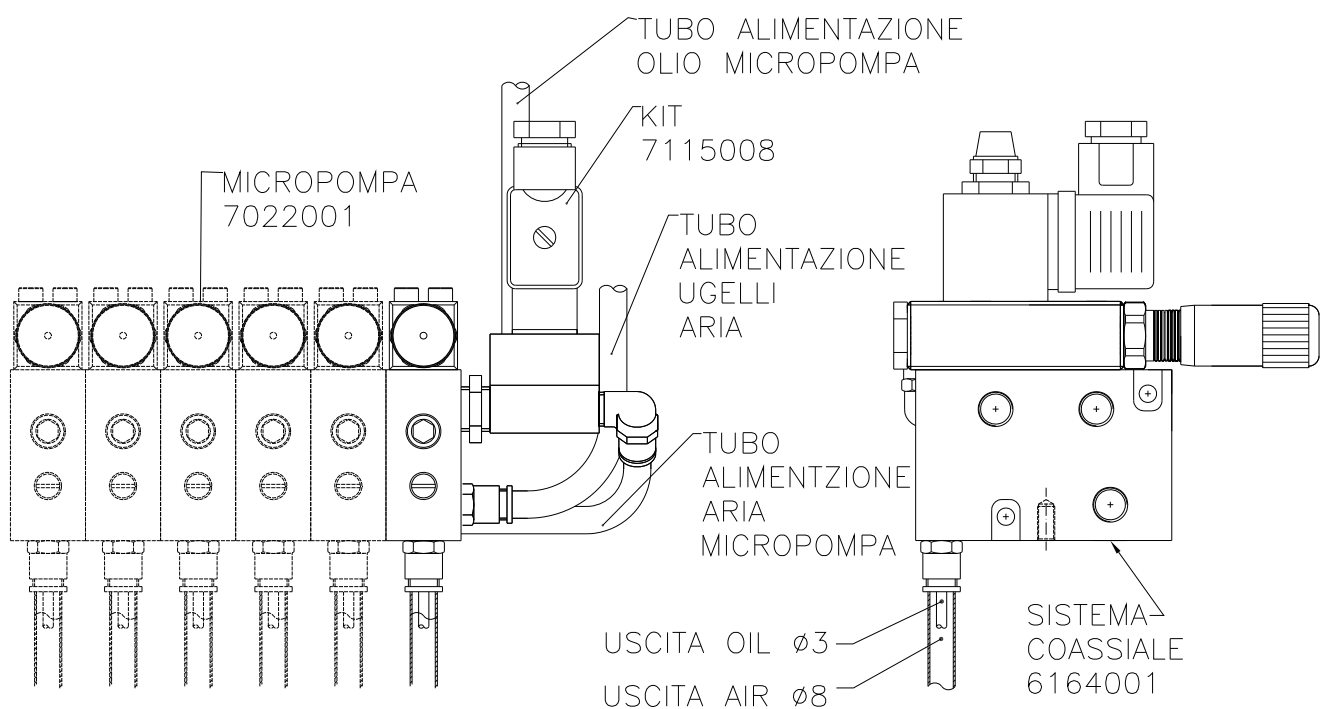



**ELETTROVALVE – SEPARATE AIR-OIL HOSES (7018030-7018035)**

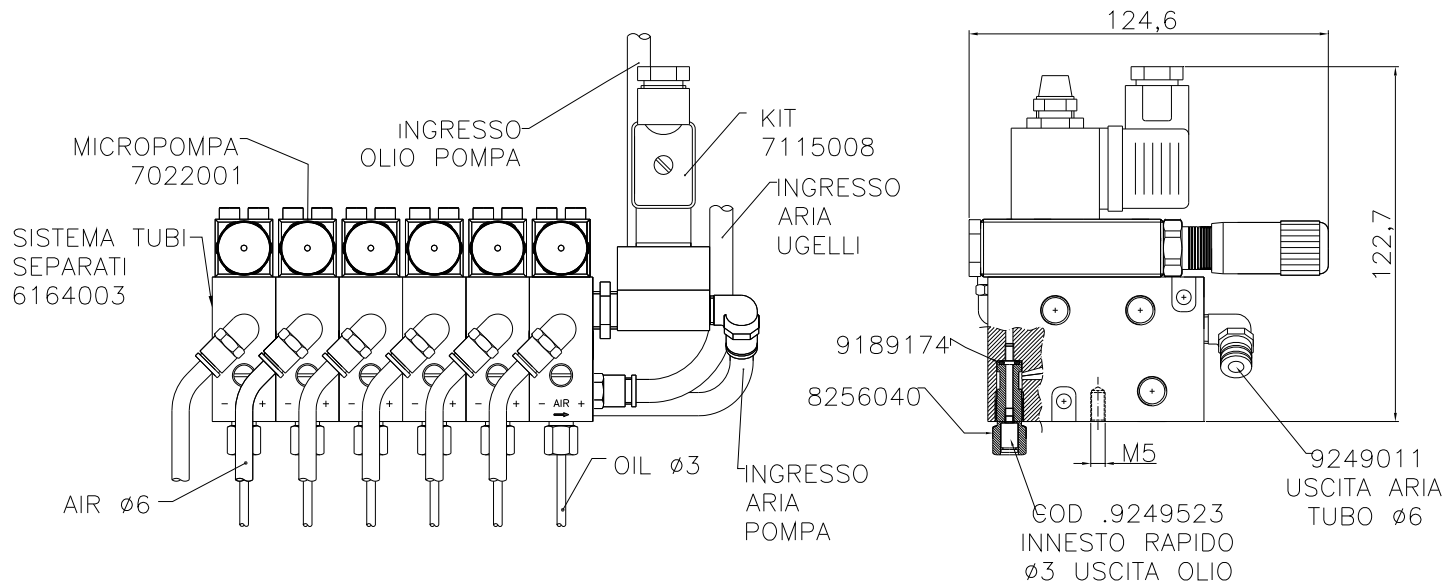

**ASSEMBLY KIT ELETTROVALVE (7115008)**

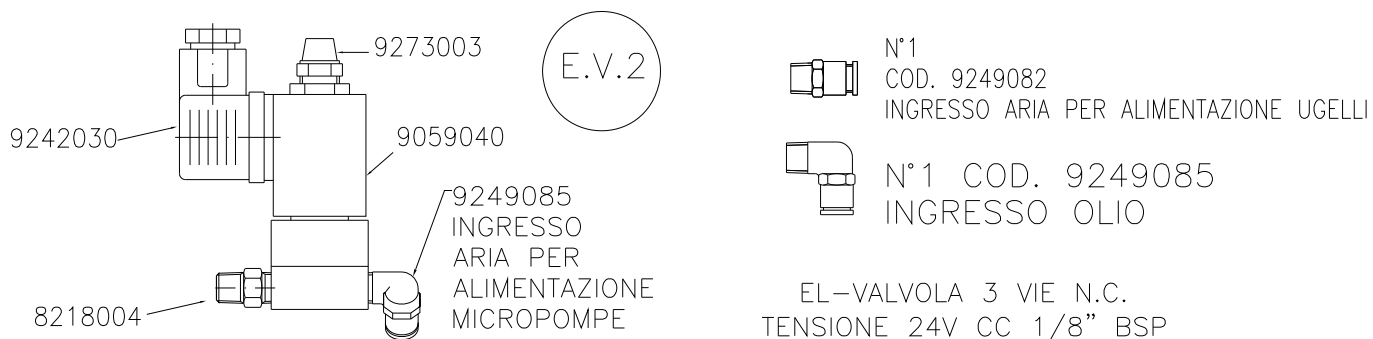

CODE COMPLETE	INITIAL BODY FOR TIMER PNEUMATIC (6164002)	INITIAL BODY FOR E-VALVE (6164005)	MICRO PUMPS (7022001)	BASE UNIT WITH COAXIAL TUBES (6164001)	BASE UNIT WITH SEPARATE TUBES (6164003)	PNEUMATIC FREQUENCY GENERATOR (9060001)	E-VALVE GROUP (OPTIONAL) ORDER SEPARATELY
7018010	●		1	●		●	
7018011	●		2	●		●	
7018012	●		3	●		●	
7018013	●		4	●		●	
7018014	●		5	●		●	
7018015	●		6	●		●	
7018018	●		1		●	●	
7018019	●		2		●	●	
7018020	●		3		●	●	
7018021	●		4		●	●	
7018022	●		5		●	●	
7018023	●		6		●	●	
7018024		●	1	●			7115008
7018025		●	2	●			7115008
7018026		●	3	●			7115008
7018027		●	4	●			7115008
7018028		●	5	●			7115008
7018029		●	6	●			7115008
7018030		●	1		●		7115008
7018031		●	2		●		7115008
7018032		●	3		●		7115008
7018033		●	4		●		7115008
7018034		●	5		●		7115008
7018035		●	6		●		7115008

**NOZZLE**

*NOZZLE WITH FLEXIBLE PIPE FOR AIR-OIL COAXIAL HOSE WITH MAGNET (7304002).*

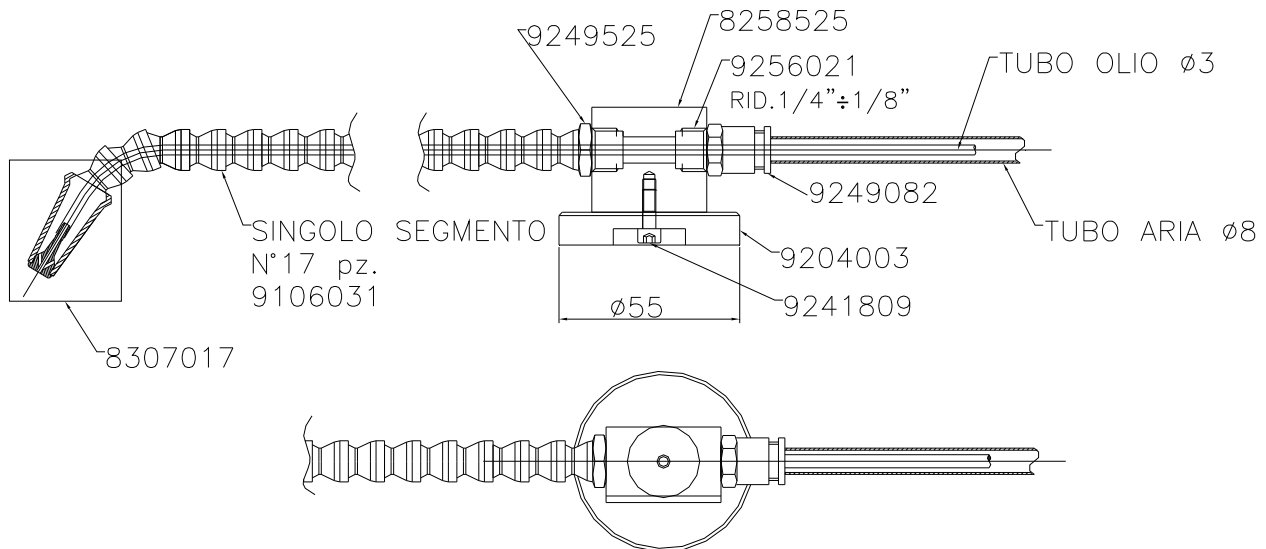

*NOZZLE FOR CUTTING BLADE WITH 2 INLETS AND 5 OUTLETS (7307003).*

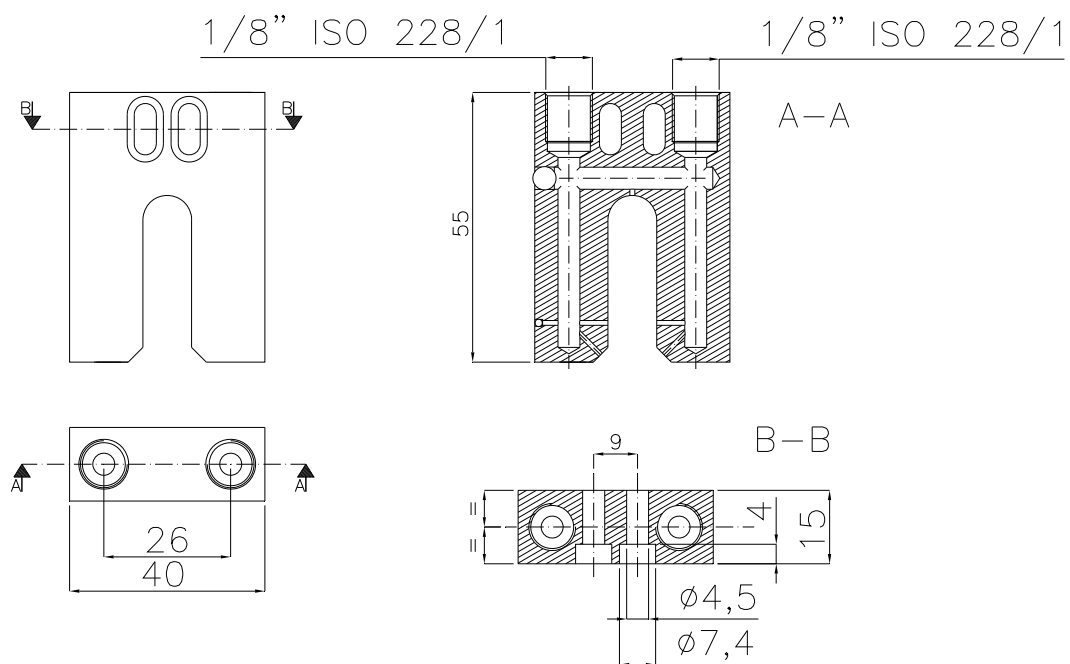

**NOZZLE FOR CUTTING BLADE WITH 1 INLETS AND 3 OUTLETS (7307004).**

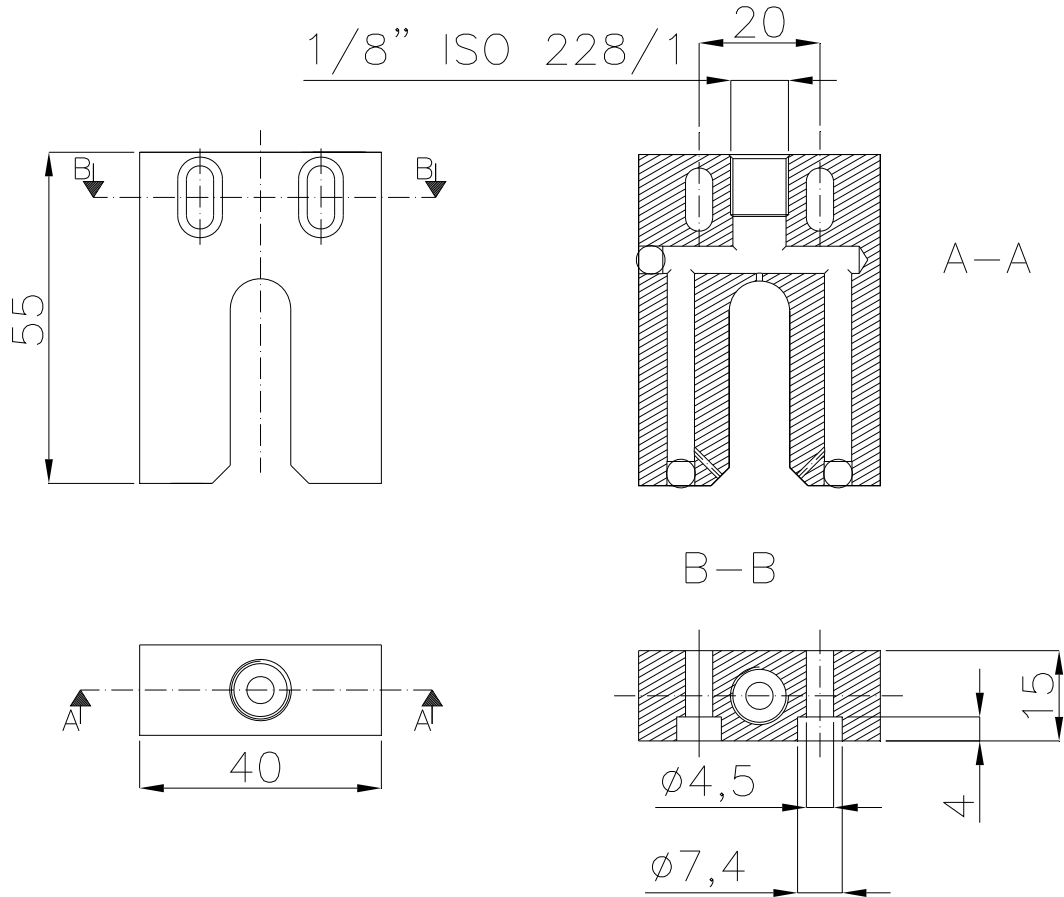

**ASSEMBLY INSTRUCTION FOR CUTTING BLADE NOZZLE**

To determine the length of the lubricant hose (Φ3) use the formula:

$$L_{oil} = L_{air} + 100mm$$

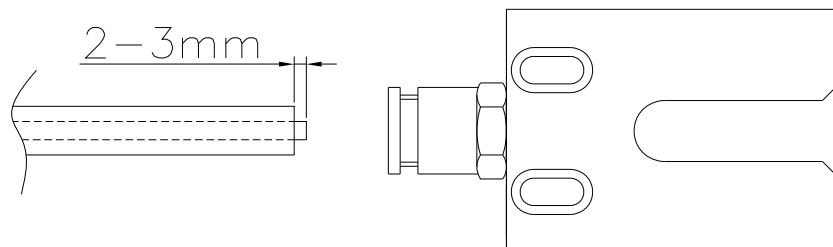

Cut the hose as in figure and connect it to the rapid fitting.

## UNPACKING AND INSTALLATION

Ensure that the packaging has not been damaged during transport. Identified a suitable place for installation open the package, unpack the equipment and then place it in a place easily accessible to the operator to avoid awkward postures. Do not install in flammable / explosive or vibrating parts.

### *HYDRAULIC CONNECTIONS*

Log on with quick coupling system between the individual pumps and lubrication points.

Use pipe diameter and 3mm 8-way systems with oil / air coaxial.

Use tubes with a diameter of 6 and 3 mm for systems with streets air / oil separate.

### *PNEUMATIC CONNECTIONS*

Connect the main air supply hose to the quick entry as required by the version of installed equipment.

### *ELECTRIC CONNECTIONS*

Make the electrical connections, paying attention to characteristics of users, depending on the version of installed equipment.

## INSTRUCTIONS

### *START OF THE SYSTEM*

Before to start do same controls:

- Check the system integrity.
- Check the electric and pneumatic connections.
- Fill the tank with lubricant oil.
- Bleed the air from loosening the drain plug (Fig. 1) located to the left side of the last sub group of the micropump. Check that the oil from getting into the pipe and wait for the release before replacing the cap. To remove the residual air, act on each bleeder screw micropump placed near to the mounting screws. Unscrew the bleed screw to wait for the leakage of the lubricant being careful not to lose the ball seat. Tighten the screw.
- Start the system with the pumps at max delivery.
- Check the oil and air delivery from the outlets.
- Set the delivery for each micropump.

### SET LUBRICANT DELIVERY

The delivery of each line of lubrication and determined by the corresponding adjustment of the micropump, which determines the extent to blow, and the generator frequency, which determines the number of strokes per minute.

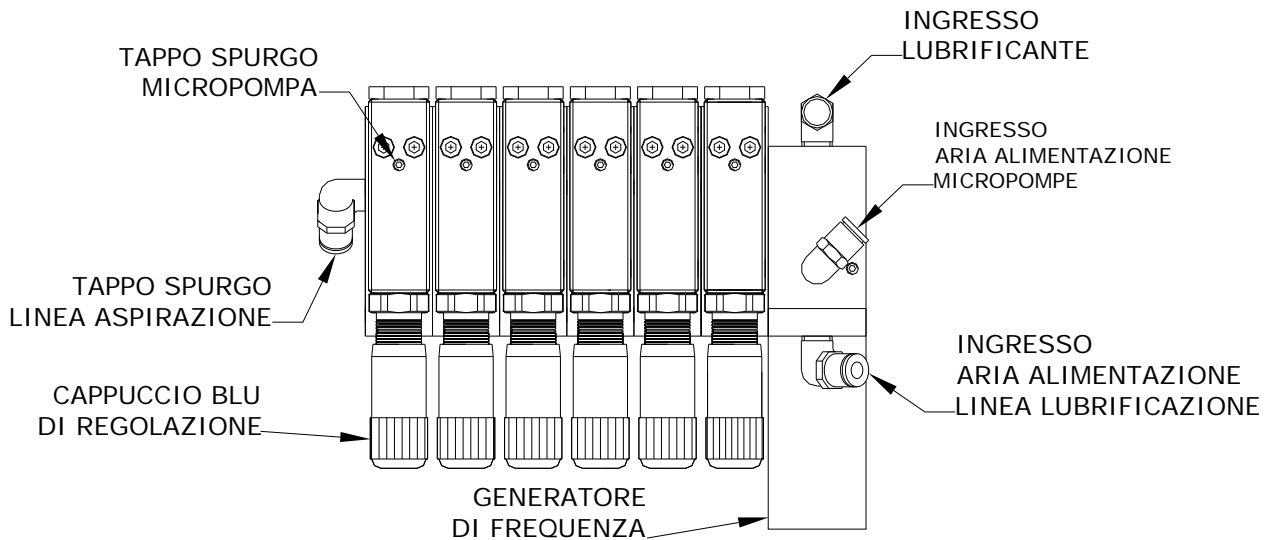

Fig. 1

To adjust the delivery of the pump action on the blue cap (Fig. 1).

Unscrew the cap there is the exclusion of the discharge

From this position, every lap and a half of the cap increases the reach of 5mm<sup>3</sup>/colpo maximum range of up to 30mm<sup>3</sup>.

For every shot of the hood is a variation of delivery 0.625mm<sup>3</sup>/stroke.

Table micropump adjustment delivery micro pump

NUMBER OF TURN	DELIVERY (mm <sup>3</sup> /stroke)
0 (unscrewed cap)	0
1.5	5
2.5	10
3.5	15
4.5	20
5.5	25
6.5	30

### FREQUENCY GENERATOR SET

Here are some settings cycles / min frequency generator with an air pressure of 6 bar. (90 psi).

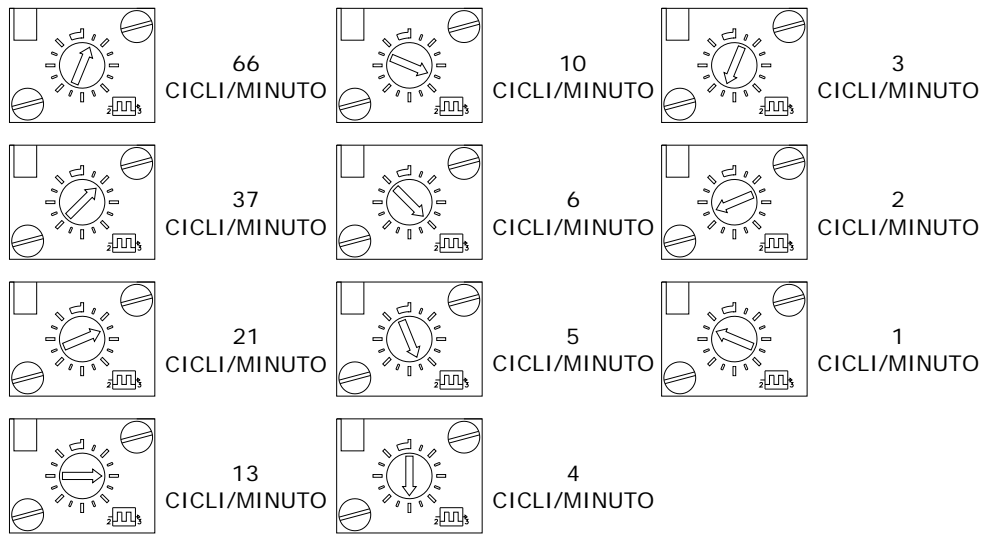

With pressure to 8 bar (120 psi) to reduce the values of 8%

With pressure to 7 bar (105 psi) to reduce the values of 4%

With pressure to 5 bar (75 psi) increases the values of 7%

### SETTING AIR FLOW

Turn clockwise to completely close the brass screw integrated into the base of the flow mixing vanishes completely. Unlike rotating counter-clockwise you will get the maximum.

Do not loosen the screw to avoid losing it. (max 3 laps).

VITE REGOLAZIONE ARIA  
LINEA DI LUBRIFICAZIONE

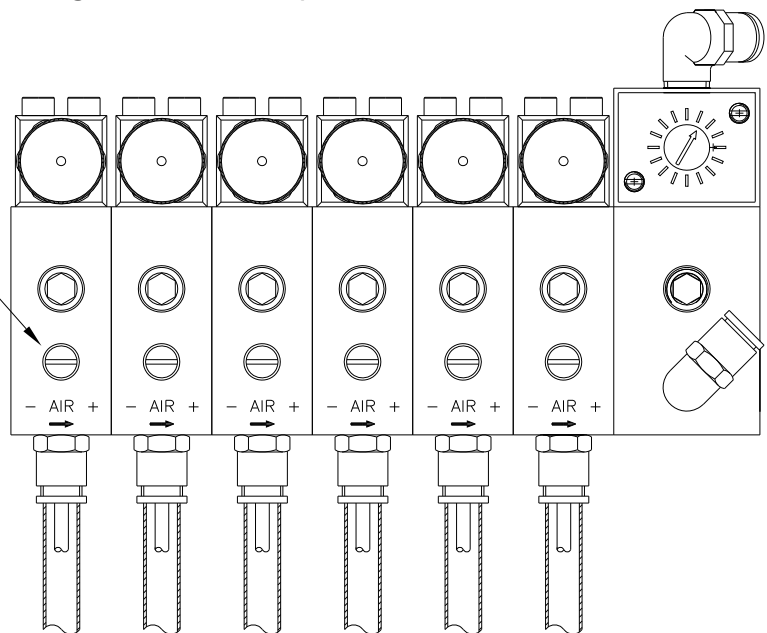

## MAINTENANCE

Before to detect any leaks is recommended to keep the equipment clean and periodically check the joints of the pipes

Control activities and / or maintenance do not require special equipment.

It is recommended to use personal protective equipment and suitable for use in ref. the Legislative Decree 626/94, and in good condition (DPR 547/55) in order to prevent danger to persons or parts of machines.

Before any maintenance make sure the power supply, hydraulics and pneumatics are disconnected.

DEFECT	CAUSE	REMEDY
The system does not deliver lubricant	Absence lubricant in the Tank	Introduce lubricant.
	The solenoid valve is not working properly	Check the electrical and pneumatic test the operation of the solenoid replace if necessary.
	The frequency generator is not working properly	Check pneumatic connection, also verify the correct operation of the generator if necessary replace it.
	Air in the circuit	Bleed the air by means of the screw.
	Absence air in the circuit	Check the circuit, then restore the minimum pressure.
	Piston blocked by valve torque screws fixing micro pump too high	Use of tightening torque values between 2 and 2.5 N/m
The system delivers only in some pumps	Delivery valves damaged or dirty	Check for dirt, then remove the obstacles and blow compressed air.
	spring Break	Substitute the spring
	Breaking seal lip.	Substitute the gasket.
	Break-ring or rings.	Substitute O-rings.
	Hydraulic or pneumatic piston blocked	Substitute the damaged part.
During the intervals are discharged one or more capillary tubes	Absence of sealing pipes in the initial connection to the pump	Remove the external tube, and then verify that the tube diameter. 3 mm is worn until it stops.
Presence of lubricant in the coaxial pipe	The lubrication pipe (3mm) is not correctly assembled in the pump.	Verify that the pipe of lubrication is worn until complete measure.

## DISPOSAL

During the maintenance or demolition disperse pollutants in the shares. For proper disposal refer to local regulations.



## TRANSPORT AND MOVEMENT

Before shipping the plants are carefully packed in cardboard boxes  
On receipt, check that the packaging is not damaged and store the equipment in a dry place.

## PRECAUTIONS

Before use please read carefully the warnings and the risks that entails the use of the system.

### *ELECTRICITY*

Do not perform operations on the machine before disconnecting the power supply, and make sure that no one can connect it during surgery.  
All equipment installed electronic, electrical, tanks and basic facilities must be connected to the ground line.

### *FLAMMABILITY*

Generally used in oil lubrication circuits is not a flammable liquid. Nevertheless, you should take all precautions to prevent it from coming into contact with hot parts or open flames.

### *PRESSURE*

Is recommended before any action to verify the absence of residual pressure in each branch of the lubrication circuit, which could cause splashing of oil during maintenance.

### *NOISE*

The lubrication system does not emit excessive noise, remaining below 70dB (A).

### *CHARACTERISTIC AIR*

Pressure at the connection point	5÷8 bar (72.5÷116 psi)
Maximum quantity of particles in suspension	15 mg/Nmc
Maximum diameter of the particles	0.05mm
Dew point	2° C (35.6°F)
Maximum quantity of oil in suspension	5 mg/Nmc

**CAUTION: Remove all grease from TANK before replacement of micropumps.**

If the oils used are natural based and compatible with the existing rules on health, we must calibrate the pressure of mixing to prevent the formation and dispersion of fog in the environment.

The pressure is indicative of mixing between 1 bar (14.7 psi) and 2.5 bar (36.7 psi).

## CONTRAINdicATIONS OF USE

The plant has no contraindications except for the following points:

- Contact with fluids from the operator, due to hose failure.
- Posture ineligible (difficult access to the plant).
- Contact with oil during the refilling / maintenance.

The operator must be equipped with appropriate PPE (tit. VIII - 626)

- Use of incorrect lubricant.

Some of the main lubricants are not allowed:

Fluid	Risks
water	Ossidazione impianto
Products corrosive	Personal injury, equipment corrosion
Foodstuff	Contamination of the same
Gasoline	Fire / explosion, seal wear
Solvents, flammable liquids	Fire / explosion, seal wear
Lubricants with abrasive additives	Consumption of plant parts
Lubricants with silicone additives	pump seizure

## RECOMMENDED SPARE PARTS

Seals and springs Micro-pumps

**IMPORTANT:** To reassemble the micropump to its base use values between 2 and 2,5 N/m. to tighten the screws (9241381).

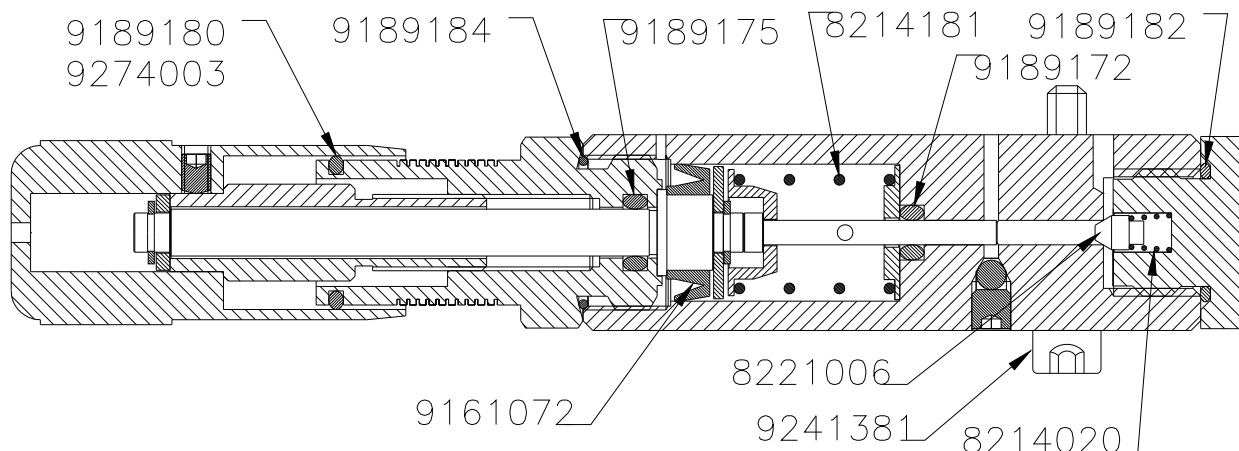

**KIT PRIMARY E. VALVE COD. 7115003**

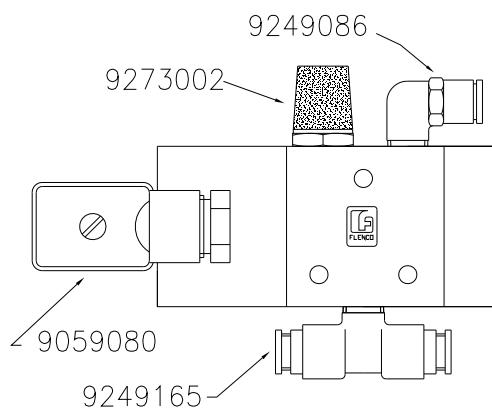

0

**E-VALVOLA 3/2 NC 24V DC**

**KIT SECONDARY E. VALVE COD. 7115008**

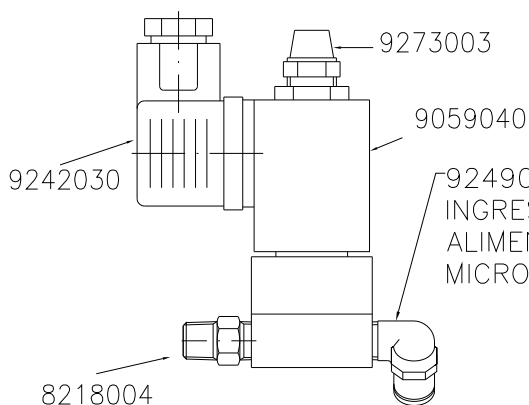

N°1 COD. 9249082  
INGRESSO ARIA PER  
ALIMENTAZIONE UGELLI



N°1 COD. 9249085  
INGRESSO OLIO



**E-VALVOLA 3 VIE NC 24V DC**

**KIT PRESSURE REGULATORE COD. 7115004**

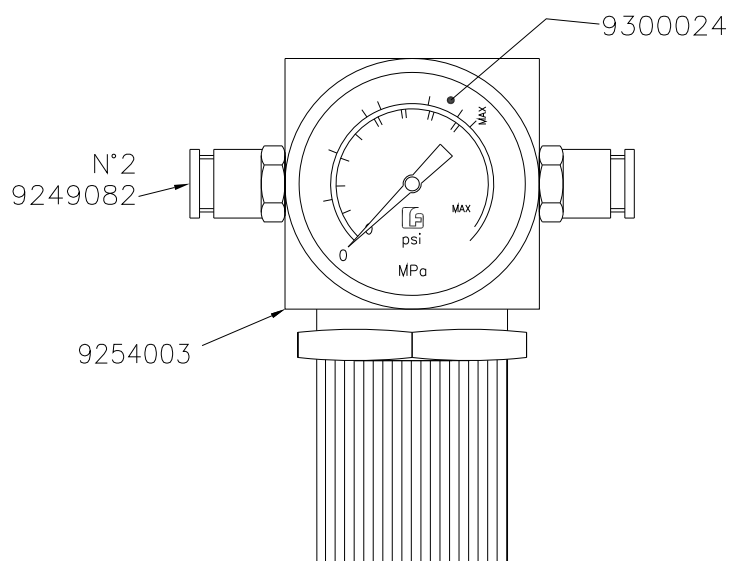





 **NEXOIL**

Nexoil s.r.l.  
Sede Legale ed Amministrativa  
Busto Arsizio (VA) Via Per Fagnano, 27 – CAP 21052  
[www.nexoil.it](http://www.nexoil.it)

This manual is property of the fluid-engineering-Nexoil s.r.l. company  
Nexoil s.r.l. reserves the right to make, at any time and without notice, changes to technical and commercial reasons.  
Reproduction of any part of this manual is prohibited by law without the written permission of Nexoil s.r.l.  
Copyright © by Nexoil s.r.l.