

Minicentrali Oleodinamiche

Hydraulic Compact Power Unit

V.08/2023

FLUID SYSTEMS MANUFACTURING

www.nexoil.it

Minicentrali Oleodinamiche

Hydraulic Compact Power Unit

Cat. Code 3320959 - 05/2023

Applicazioni tipiche

Typical applications

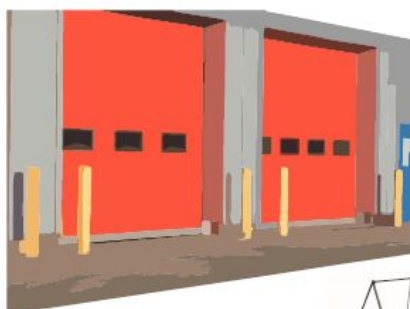

- **Sollevatori auto** - Car lifters
- **Piattaforme di sollevamento** - Lifting platforms
- **Ribaltabili** - Dump Trucks
- **Livellatori di carico** - Tail lifts
- **Rampe di carico** - Dock levelers
- **Portoni sezionali industriali** - Sectional industrial doors
- **Smontagomme** - Tyre changer
- **Presse** - Presses
- **Spaccalegna** - Log splitters
- **Segatrici a nastro** - Bandsaw machines
- **Macchine utensili** - CNC Machines
- **Gru idrauliche** - Hydraulic Cranes
- **Piegatrici** - Bending machines
- **Sistemi di parcheggio** - Parking systems
- **Torri faro** - Lighting towers
- **Passerelle idrauliche** - Hydraulic gangways
- **Macchine per il vetro** - Glass making machines
- **Macchine per la lavorazione della pietra** - Stone processing machines
- **Aspi avvolgitori e svolgitori** - Uncoilers and recoilers

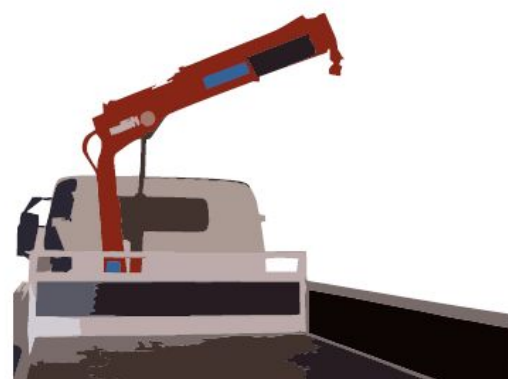
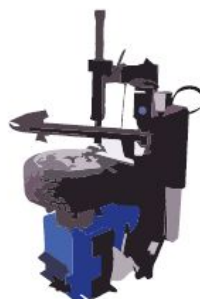

Indice sinottico

Synoptic index

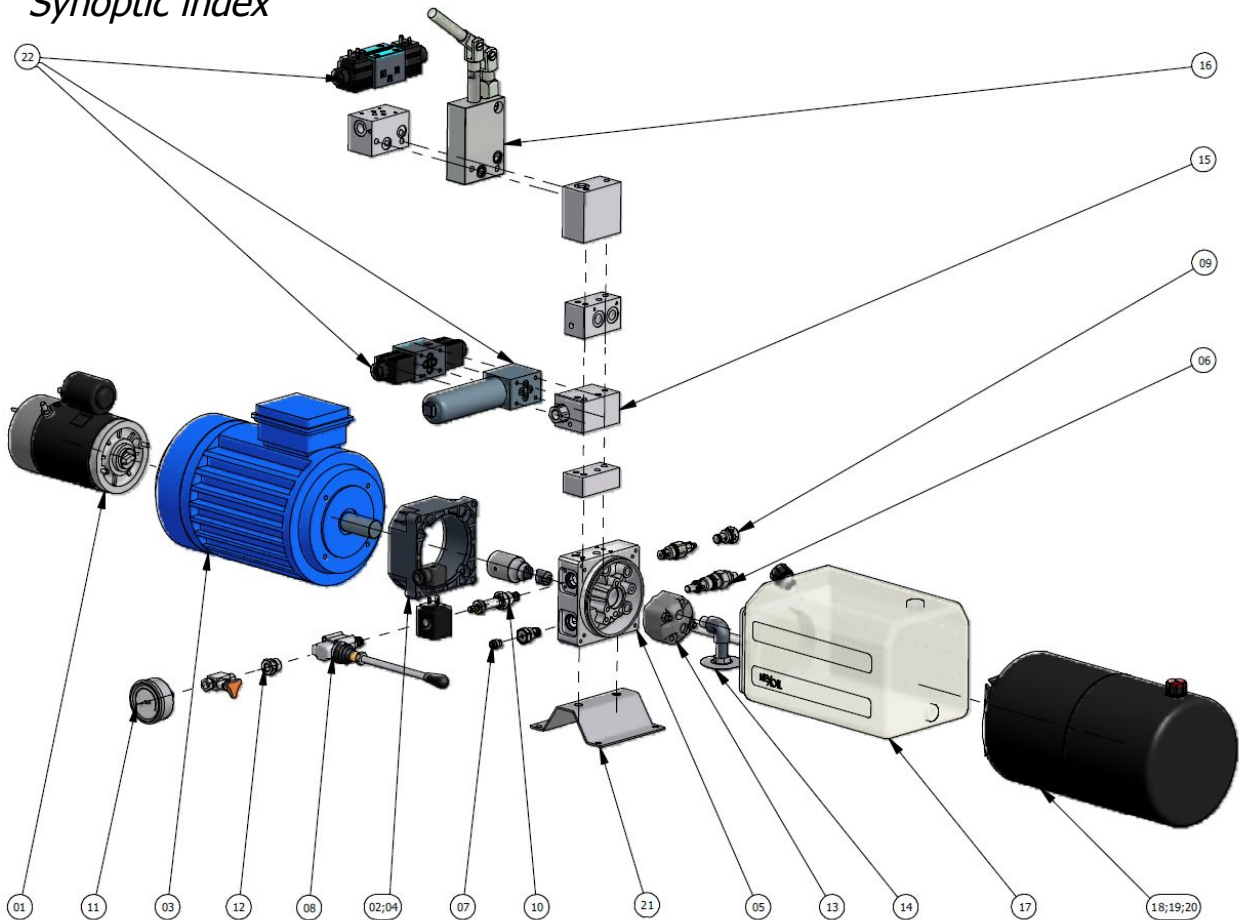

Ref. **Sezione**

- 01 **Motori elettrici in corrente continua e accessori -**
- 02 **Accoppiamenti motori elettrici C.C.**
- 03 **Motori elettrici in corrente alternata**
- 04 **Parti per accoppiamento motori elettrici C.A.**
- 05 **Corpi centrali**
- 06 **Valvole di massima pressione**
- 07 **Valvole di ritegno**
- 08 **Valvole ad azionamento manuale, pneumatiche, altre**
- 09 **Valvole di controllo di flusso**
- 10 **Elettrovalvole a cartuccia**
- 11 **Manometri, pressostati e accessori**
- 12 **Tappi SAE per cavità corpo centrale e raccordi**
- 13 **Pompe ad ingranaggi**
- 14 **Filtri e componenti per aspirazione e scarico**
- 15 **Blocchi e valvole modulari cetop3**
- 16 **Pompe di emergenza manuali**
- 17 **Serbatoi in plastica**
- 18 **Serbatoi cilindrici in acciaio**
- 19 **Serbatoi rettangolari in acciaio con coperchio**
- 20 **Serbatoi rettangolari in acciaio con collare**
- 21 **Accessori**
- 22 **Valvole e accessori modulari Cetop3**

Section

- Direct current electric motors and accessories*
- DC electric motors couplings*
- Standard alternate current motors*
- AC Electric motors coupling accessories*
- Central manifolds*
- Relief valves*
- Check valves*
- Hand operated, pneumatic and other valves*
- Flow control valves*
- Solenoid cartridge valves*
- Pressure gauges / switches and accessories*
- SAE plugs for central manifold and fittings*
- Gear pumps*
- Filters, suction and return line components*
- Cetop3 modular valves and manifolds*
- Emergency hand operated pumps*
- Plastic tanks*
- Cylindrical steel tanks*
- Rectangular steel tanks with cover*
- Rectangular steel tanks with collar*
- Accessories*
- Cetop3 modular valves and accessories*

01 Motori elettrici in corrente continua e accessori

Direct current electric motors and accessories

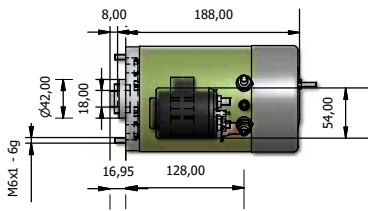

R9083604

Motore 12V C.C. D.114mm con protezione termica e teleruttore di avviamento (DX)
 12V D.114mm DC Motor with thermal protection and starting switch (CW)
 12V DC 1.600W 200A 2.650 rpm S2 2 min S3 5% ED 7,4 kg

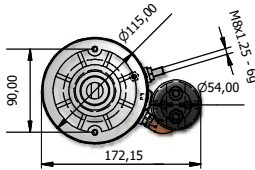

R9083613

Motore 24V C.C. D.114mm con protezione termica e teleruttore di avviamento (DX)
 24V D.115mm DC Motor with thermal protection and starting switch (CW)
 24V DC 2.200W 200A 2,600 rpm S2 2 min S3 5% ED 7,6 kg

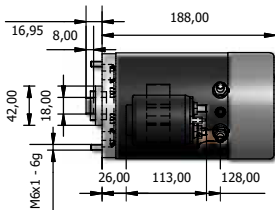

R9083602 AMJ-5197

Motore 12V C.C. D.115mm con protezione termica e teleruttore di avviamento (DX)
 12V D.115mm DC Motor with thermal protection and starting switch (CW)
 12V DC 1,600W 230A 2.750 rpm S2 3 min S3 7,5% ED 7,2 kg

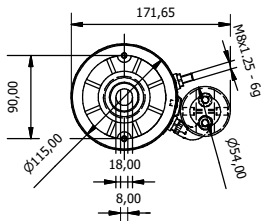

R9083631 AMJ-5196

Motore 24V C.C. D.115mm con protezione termica e teleruttore di avviamento (DX)
 24V D.115mm DC Motor with thermal protection and starting switch (CW)
 24V DC 2,200W 120A 2,600 rpm S2 1,2 min S3 4,5% ED 7,2 kg

R9083601

Motore 12V C.C. D.80 mm con protezione termica (Bidirezionale)
 12V D.80 mm DC Motor with thermal protection (Bidirectional)
 12V DC 500W 70A 2,300 rpm S2 2,5 min S3 10% ED 3,0 kg

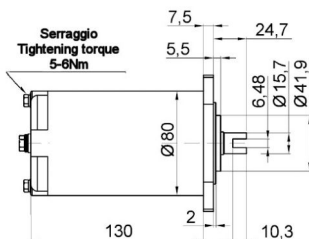

R9083607

Motore 12V C.C. D.80 mm con protezione termica (Bidirezionale)
 12V D.80 mm DC Motor with thermal protection (Bidirectional)
 12V DC 800W 90A 3,100 rpm S2 2,5 min S3 10% ED 3,0 kg

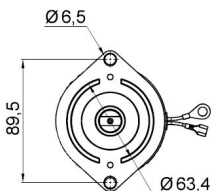

R9083606

Motore 24V C.C. D.80 mm con protezione termica (Bidirezionale)
 24V D.80 mm DC Motor with thermal protection (Bidirectional)
 24V DC 500W 35A 2,400 rpm S2 2,5 min S3 10% ED 3,0 kg

R9083638

Motore 24V C.C. D.80 mm con protezione termica (Bidirezionale)
 24V D.80 mm DC Motor with thermal protection (Bidirectional)
 24V DC 800W 35A 3,100 rpm S2 2,5 min S3 10% ED 3,0 kg

01 Motori elettrici in corrente continua e accessori

Direct current electric motors and accessories

R9295001 ST12

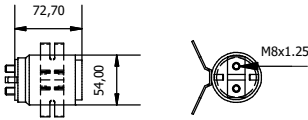

Interruttore di avviamento 12V 150A 12V 150A starting switch

Corrente nominale 150A
Nominal current 150A

Corrente di picco 350A
Short time current 350A

Tensione nominale 12V DC
Rated voltage 12V DC

Corrente massima in continuo $\leq 150A$
Maximum permanent current $\leq 150A$

Temperatura di lavoro -20 + 50°C
Working temperature -20 + 50°C

R9295003 ST24



Interruttore di avviamento 24V 150A 24V 150A starting switch

Corrente nominale 150A
Nominal current 150A

Corrente di picco 350A
Short time current 350A

Tensione nominale 24V DC
Rated voltage 24V DC

Corrente massima in continuo $\leq 150A$
Maximum permanent current $\leq 150A$

Temperatura di lavoro -20 + 50°C
Working temperature -20 + 50°C

R7115152 KST-90



Kit montaggio teleruttore motore C.C. D.80 mm Starting switch assembly kit D.80 DC Motor

R8278002 Treccia in rame isolata L=80 mm
TCU80 Isolated copper braid L=80 mm

R9155003 Fascetta avvitabile inox D=90 mm
KC90 Screw-on stainless steel band D=90 mm

R7115151 KST-130

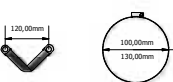

Kit montaggio teleruttore motore C.C. D.112-114 mm Starting switch assembly kit D.112-114 DC Motor

R9147001 Treccia in rame isolata L=120 mm
TCU120 Isolated copper braid L=120 mm

R9155002 Fascetta avvitabile inox D=130 mm
KC130 Screw-on stainless steel band D=130 mm

02 Accoppiamenti per motori in C.C.

DC electric motors couplings

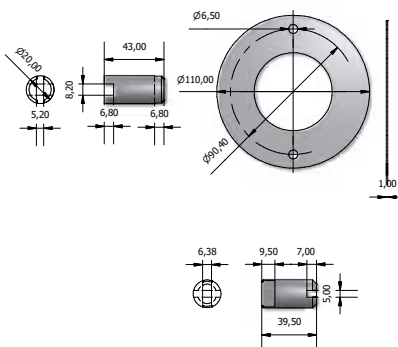

R7115102 Kit accoppiamento motore C.C. D.114-115 (XF-114) Coupling kit DC motor D-114-115

R8283010 Giunto motore - pompa D.114-115
X114 Motor - pump coupling for D.114-115 motors

R8177051 Distanziale motore C.C. D.114-115
F09 D.114-115 DC motor spacer

R8283009 Giunto motori C.C. magneti permanenti D.80 (X80) Permanent magnet DC motor coupling

03 Motori elettrici in corrente alternata

AC electric motors

IEC-B14-71

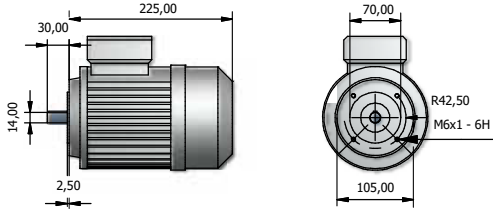

Trifase 2/ 4 poli Threephase 2/ 4 poles

- B14 0,25 AC 3-4P 71A4
- B14 0,37 AC 3-4P 71B4
- B14 0,37 AC 3-2P 71B4
- B14 0,55 AC 3-2P 71B2

Monofase 2 / 4 poli Single phase 2 / 4 poles

- B14 0,25 AC S-4P 71A4
- B14 0,37 AC S-4P 71B4
- B14 0,37 AC S-2P 71A2
- B14 0,55 AC S-2P 71B2

IEC-B14-80

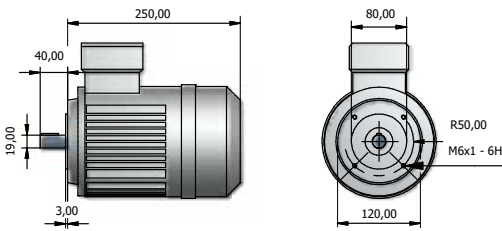

Trifase 2/ 4 poli Threephase 2/ 4 poles

- B14 0,75 AC 3-4P 80B4
- B14 0,55 AC 3-4P 80A4
- B14 0,75 AC 3-4P 80B4 IE1
- B14 0,75 AC 3-2P 80A2
- B14 1,1 AC 3-2P 80B2
- B14 0,75 AC 3-2P 80A2 IE1
- B14 1,1 AC 3-2P 80B2 IE1

Monofase 2 / 4 poli Single phase 2 / 4 poles

- B14 0,55 AC S-4P 80A4
- B14 0,75 AC S-4P 80B4
- B14 0,75 AC S-2P 80A2
- B14 1,1 AC S-2P 80B2

IEC-B14-90

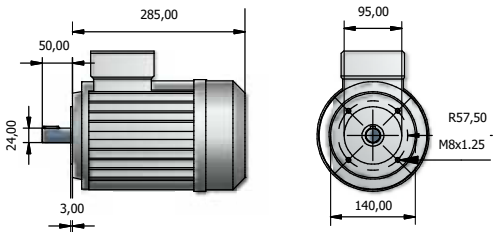

Trifase 2/ 4 poli Threephase 2/ 4 poles

- B14 1,1 AC 3-4P 90S4
- B14 1,5 AC 3-4P 90L4
- B14 1,1 AC 3-4P 90S4 IE1
- B14 1,5 AC 3-4P 90L4 IE1
- B14 1,5 AC 3-2P 90S2
- B14 2,2 AC 3-2P 90L2
- B14 1,5 AC 3-2P 90S2 IE1
- B14 2,2 AC 3-2P 90L2 IE1

Monofase 2 / 4 poli Single phase 2 / 4 poles

- B14 1,1 AC S-4P 90S4
- B14 1,5 AC S-4P 90L4
- B14 1,5 AC S-2P 90S2
- B14 2,2 AC S-2P 90L2

IEC-B14-100

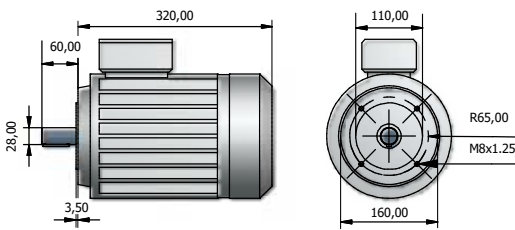

Trifase 2/ 4 poli Threephase 2/ 4 poles

- B14 2,2 AC 3-4P 100LA4
- B14 3,0 AC 3-4P 100LB4
- B14 4,0 AC 3-4P 100LB4
- B14 2,2 AC 3-4P 100LA4 IE1
- B14 3,0 AC 3-4P 100LB4 IE1
- B14 3,0 AC 3-2P 100L2
- B14 3,0 AC 3-2P 100L2 IE1

Monofase 2 / 4 poli Single phase 2 / 4 poles

- B14 2,2 AC S-4P 100LA4
- B14 3,0 AC S-4P 100LB4
- B14 3,0 AC S-2P 100L2

IEC-B14-112

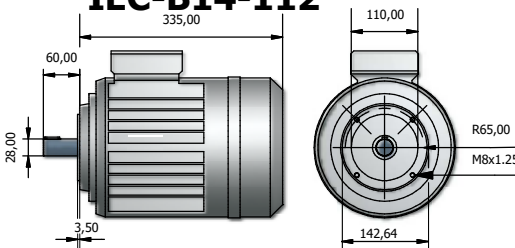

Trifase 2/ 4 poli Threephase 2/ 4 poles

- B14 4,0 AC 3-4P 112M4 IE1
- B14 4,0 AC 3-2P 112M2
- B14 4,0 AC 3-2P 112M2 IE1

B14 - * - AC * - * P - ***** - *****

kW

kW

S = monofase

3 = Trifase

S = singlephase

3 = threephase

N° di poli

N° of poles

Taglia IEC

IEC size

Classe di efficienza IE1 o IE2 se omessa

Efficiency class IE1 or IE2 if omitted

04 Accoppiamenti per Motori elettrici C.A.

AC electric motors coupling accessories

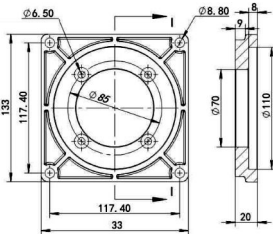

R7115124
XB14-71-TA

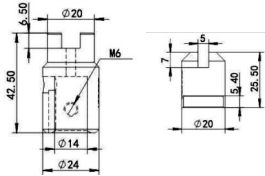

Kit accoppiamento motori AC IEC 71
Coupling kit AC motor IEC 71

R9177001
FA71-TA

Flangia motore IEC 71
Motor flange IEC 71

R9283011
X01-TA

Giunto lato motore IEC 71
Motor side coupling IEC 71

R9283015
X00-TA

Giunto lato pompa motori AC IEC
Pump side AC IEC Motors

Assemblaggio lato corpo: 4 x viti DIN 6921 M8 x 25
Assemblaggio lato motore: 4 x viti DIN 912 M6 x 16
Giunto motore: 1 x vite DIN 913 M6 x 8

Manifold side assembly: 4 x screws DIN 6921 M8 x 25
Motor side assembly: 4 x screws DIN 912 M6 x 16
Motor coupling: 1 x screw DIN 913 M6 x 8

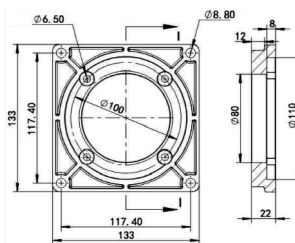

R7115125
XB14-80-TA

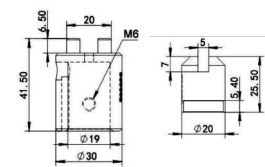

Kit accoppiamento motori AC IEC 80
Coupling kit AC motor IEC 80

R9177002
FA80-TA

Flangia motore IEC 80
Motor flange IEC 80

R9283012
X02-TA

Giunto lato motore IEC 80
Motor side coupling IEC 80

R9283015
X00-TA

Giunto lato pompa motori AC IEC
Pump side AC IEC Motors

Assemblaggio lato corpo: 4 x viti DIN 6921 M8 x 25
Assemblaggio lato motore: 4 x viti DIN 912 M6 x 16
Giunto motore: 1 x vite DIN 913 M6 x 8

Manifold side assembly: 4 x screws DIN 6921 M8 x 25
Motor side assembly: 4 x screws DIN 912 M6 x 16
Motor coupling: 1 x screw DIN 913 M6 x 8

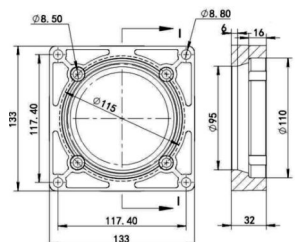

R7115126
XB14-90-TA

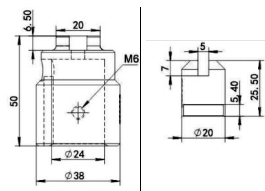

Kit accoppiamento motori AC IEC 90
Coupling kit AC motor IEC 90

R9177003
FA90-TA

Flangia motore IEC 90
Motor flange IEC 90

R9283013
X03-TA

Giunto lato motore IEC 90
Motor side coupling IEC 90

R9283015
X00-TA

Giunto lato pompa motori AC IEC
Pump side AC IEC Motors

Assemblaggio lato corpo: 4 x viti DIN 6921 M8 x 30
Assemblaggio lato motore: 4 x viti DIN 912 M8 x 16
Giunto motore: 1 x vite DIN 913 M6 x 8

Manifold side assembly: 4 x screws DIN 6921 M8 x 30
Motor side assembly: 4 x screws DIN 912 M8 x 16
Motor coupling: 1 x screw DIN 913 M6 x 8

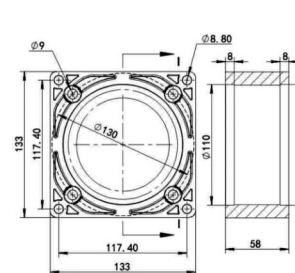

R7115127
XB14-100-TA

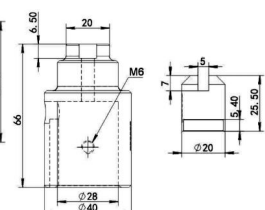

Kit accoppiamento motori AC IEC 100/112
Coupling kit AC motor IEC 100/112

R9177004
FA100-TA

Flangia motore IEC 100/112
Motor flange IEC 100/112

R9283014
X04-TA

Giunto lato motore IEC 100/112
Motor side coupling IEC 100/112

R9283015
X00-TA

Giunto lato pompa motori AC IEC
Pump side AC IEC Motors

Assemblaggio lato corpo: 4 x viti DIN 6921 M8 x 30
Assemblaggio lato motore: 4 x viti DIN 912 M8 x 55
Giunto motore: 1 x vite DIN 913 M6 x 8

Manifold side assembly: 4 x screws DIN 6921 M8 x 55
Motor side assembly: 4 x screws DIN 912 M8 x 55
Motor coupling: 1 x screw DIN 913 M6 x 8

05 Corpo centrale
Central manifold

Dimensioni Generali
General dimensions

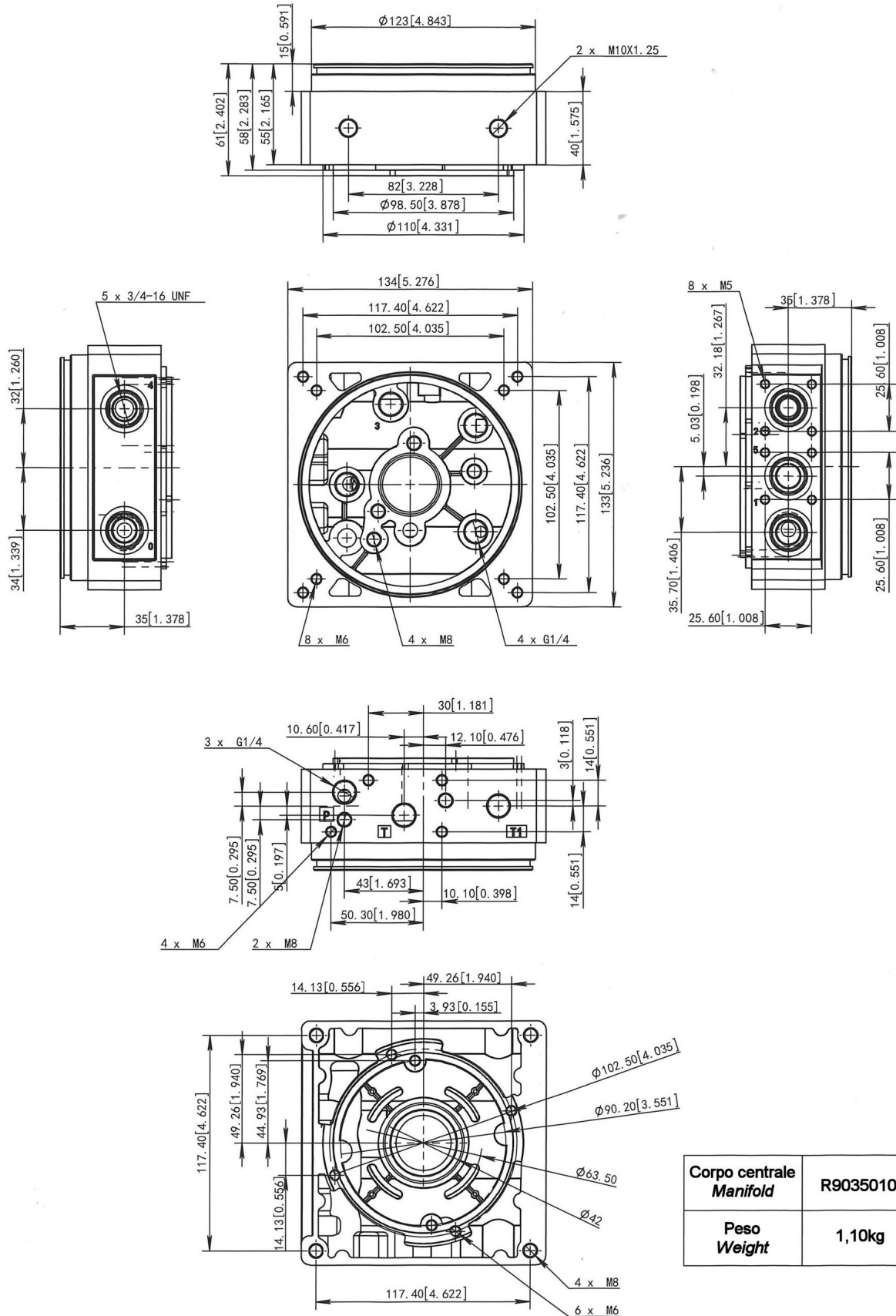

Corpo centrale Manifold	R9035010
Peso Weight	1,10kg

05 Corpo centrale

Central manifold

Cavità e Componenti

Cavities and Components

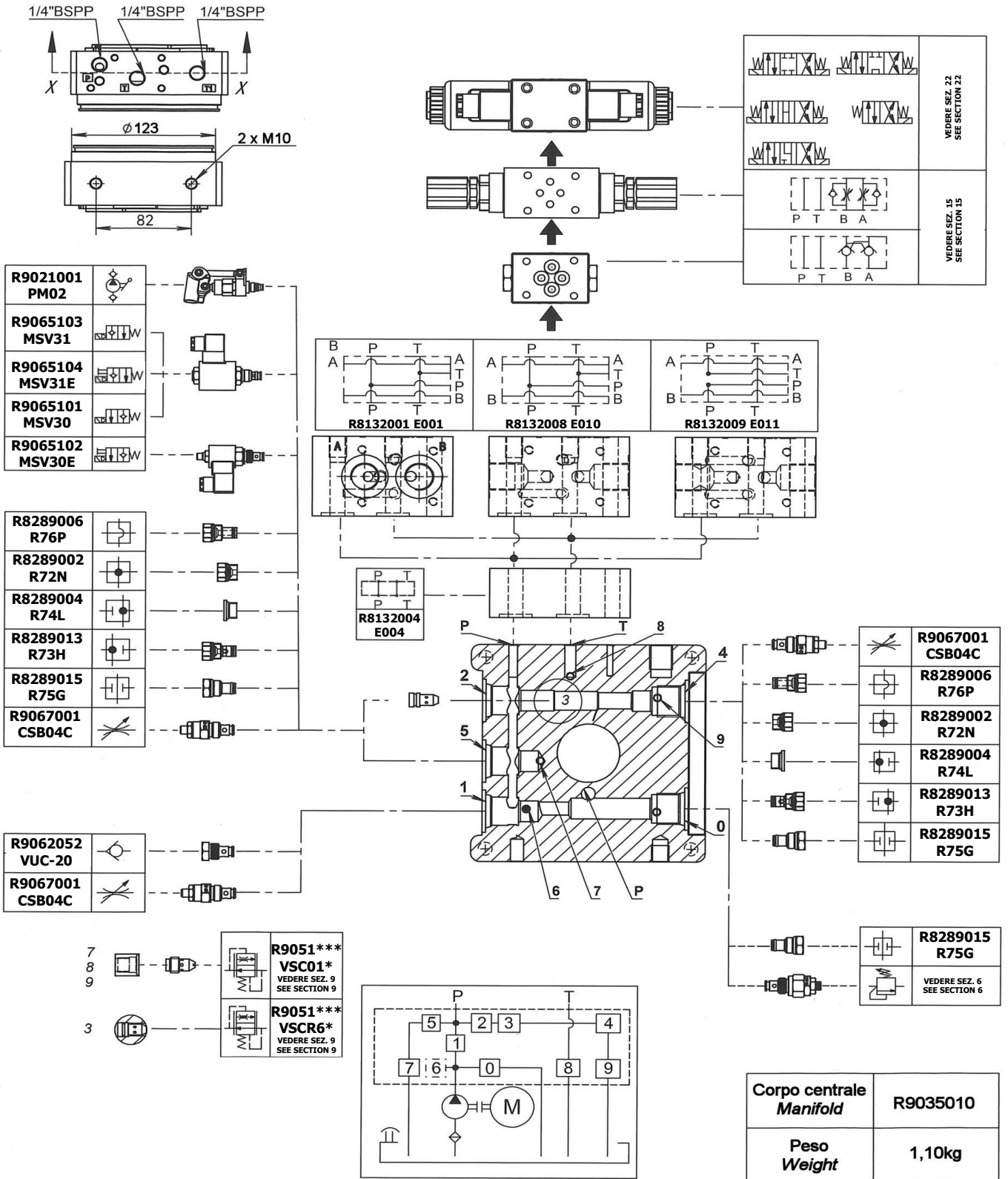

Corpo centrale Manifold	R9035010
Peso Weight	1,10kg

06 Valvole di massima pressione

Relief Valve (security valves)

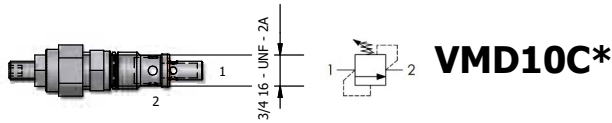

1
 Campo di taratura 10 - 40 bar
 Set pressure range 10 - 40 bar
R9050020
VMD10C1

2
 Campo di taratura 20 - 110 bar
 Set pressure range 20 - 110 bar
R9050009
VMD10C2

3
 Campo di taratura 30 - 210 bar
 Set pressure range 30 - 210 bar
R9050010
VMD10C3

4
 Campo di taratura 40 - 350 bar
 Set pressure range 40 - 350 bar
R9050021
VMD10C4

Valvole di massima pressione ad azione diretta SAE 8
Direct acting pressure relief valves SAE 8

Portata massima 20 l/min
 Max flow 20 l/min
 Coppia di serraggio 25 - 30 Nm
 Tightening torque 25 - 30 Nm

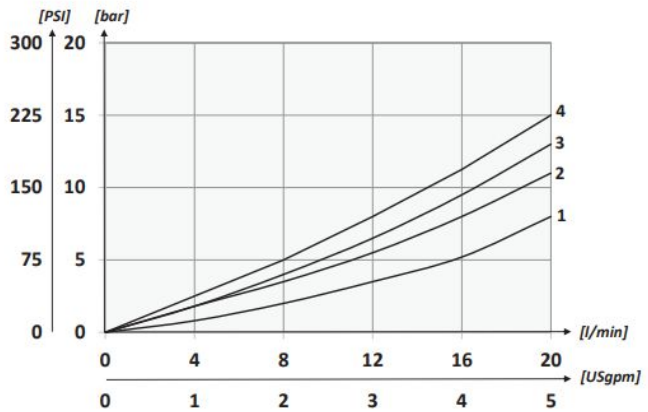

07 Valvole di ritegno

Check valves

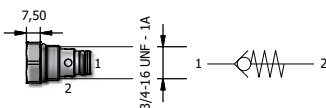

Portata massima 25 lt/min
 Max flow 25 lt/min
R9062052
VUC-20
 Pressione massima 350 bar
 Max pressure 350 bar

Valvola unidirezionale a sfera SAE08 2A
Ball type check valve SAE08 2A

Coppia di serraggio 25 - 30 Nm
 Tightening torque 25 - 30 Nm

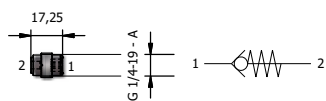
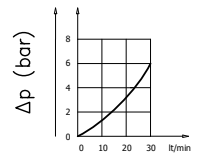

Portata massima 20 lt/min
 Max flow 20 lt/min
R9062051
VUI01-05
 Pressione massima 350 bar
 Max pressure 350 bar

Valvola unidirezionale integrata a sfera
Disk type integrated check valve

(Il montaggio richiede chiave dedicata)
 (Mounting requires special tool)

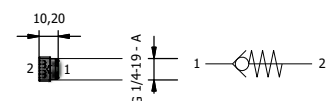
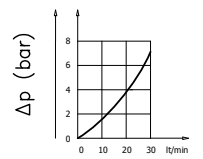

Portata massima 20 lt/min
 Max flow 20 lt/min
R9062101
VUP-140
 Pressione massima 500 bar
 Max pressure 500 bar

Valvola unidirezionale integrata a disco
Disk type in-body check valve

(Il montaggio richiede chiave dedicata)
 (Mounting requires special tool)

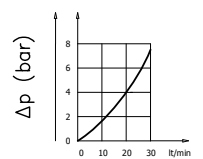

08 Valvole a comando manuale, pneumatico e altre

Hand operated, pneumatic and other valves

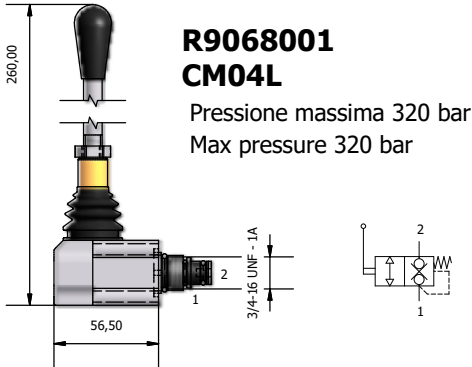

**R9068001
CM04L**

Pressione massima 320 bar
Max pressure 320 bar

Valvole direzionale a due vie a cartuccia SAE08 2A con comando a leva
Lever operated 2 way SAE08 directional valve

Portata massima 25 lt/min
Max flow 25 lt/min

Coppia di serraggio 25 - 30 Nm
Tightening torque 25 - 30 Nm

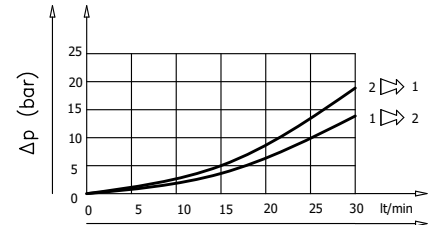

**R9062301
CPE04P**

Pressione massima 320 bar
Max pressure 320 bar

Valvole direzionale a due vie a cartuccia SAE08 2A con comando a pulsante
Button operated 2 way SAE08 directional valve

Portata massima 30 lt/min
Max flow 30 lt/min

Coppia di serraggio 25 - 30 Nm
Tightening torque 25 - 30 Nm

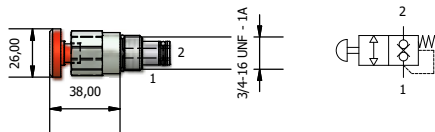
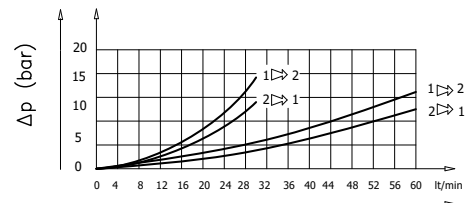

**R9061001
VPN6**

Pressione massima 350 bar
Max pressure 350 bar

Valvole direzionale a due vie a cartuccia SAE08 2A con comando a pulsante
Button operated 2 way SAE08 directional valve

Portata massima 40 lt/min
Max flow 40 lt/min

Pressione di pilotaggio 4 - 15 bar
Piloting pressure 4 - 15 bar

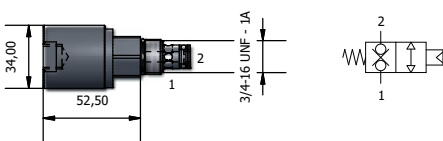
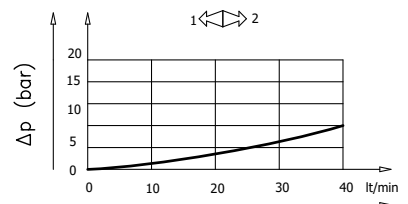

**R9065106
CDE-20**

Pressione massima 210 bar
Max pressure 210 bar

Valvola di scarico automatico a 3 vie con uscita in linea M18 x 1.5
3 way in-line outlet automatic unloading valve M18 x 1.5

Portata nominale 12 lt/min
Nominal flow 12 lt/min

Cavità metrica M18 x 1.5
Metric cavity M18 x 1.5

Pressione di commutazione 14 bar
(molla 5 bar a richiesta)

Commutation pressure 14 bar
(5 bar spring on request)

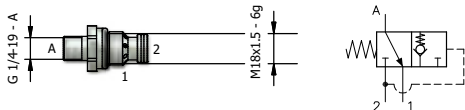
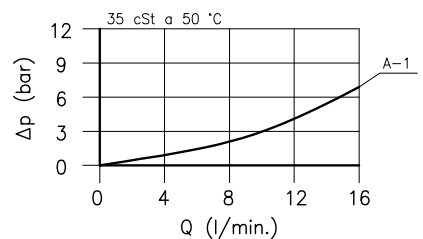

09 Valvole di controllo di flusso

Flow control valves

R9067001 CSB04C

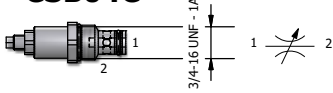

Regolatore di flusso non compensato a taratura variabile Adjustable not compensated flow regulator

Pressione massima 300 bar Portata massima 30 lt/min
Max pressure 300 bar Max flow 30 lt/min

Coppia di serraggio 25 - 30 Nm
Tightening torque 25 - 30 Nm

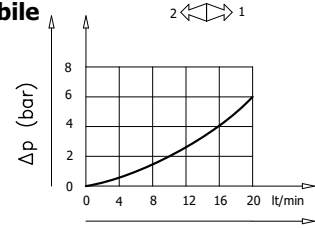

R9067*** CSC04C

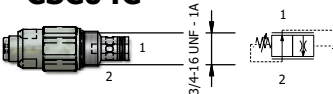

Regolatore di flusso compensato a taratura variabile Compensated adjustable flow regulator

Pressione massima 350 bar Portata massima 18 lt/min
Max pressure 350 bar Max flow 18 lt/min

Coppia di serraggio 25 - 30 Nm
Tightening torque 25 - 30 Nm

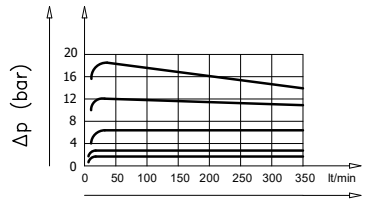

R9067009 VCFUX-V

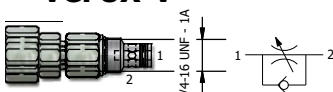

Regolatore di flusso unidirezionale a taratura variabile Unidirectional adjustable flow regulator

Pressione massima 350 bar Portata massima 40 lt/min
Max pressure 350 bar Max flow 40 lt/min

Coppia di serraggio 25 - 30 Nm
Tightening torque 25 - 30 Nm

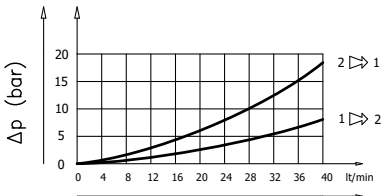

R9051*** VSC01*



Pressione massima 250 bar
Max pressure 250 bar
Portata massima 12 lt/min
Max flow 12 lt/min
Coppia di serraggio 6 Nm
Tightening torque 6 Nm

Regolatore di flusso integrato compensato a taratura fissa In-body compensated flow regulator fixed setting

- | | | | |
|--------------|------------|--------------|-----------------------------|
| 001-A | 1,0 lt/min | 007-H | 8,0 lt/min |
| 002-B | 2,0 lt/min | 008-L | 9,0 lt/min |
| 003-C | 3,0 lt/min | 009-M | 10 lt/min |
| 004-D | 4,0 lt/min | 026-N | 11 lt/min |
| 005-E | 5,0 lt/min | 027-O | 12 lt/min |
| 006-F | 6,0 lt/min | 032-X | Da forare/
To be drilled |
| 025-G | 7,0 lt/min | | |

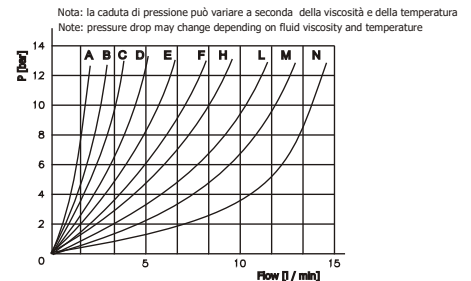

R9051*** VSCR6*

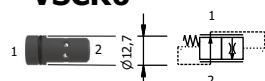

Pressione massima 250 bar
Max pressure 250 bar
Portata massima 12 lt/min
Max flow 12 lt/min

Regolatore di flusso integrato compensato a taratura fissa In-body compensated flow regulator fixed setting

- | | | | |
|--------------|------------|---------------|-----------------------------|
| 010-1 | 1,0 lt/min | 017-8 | 8,0 lt/min |
| 011-2 | 2,0 lt/min | 018-9 | 9,0 lt/min |
| 012-3 | 3,0 lt/min | 019-10 | 10 lt/min |
| 013-4 | 4,0 lt/min | 020-11 | 11 lt/min |
| 014-5 | 5,0 lt/min | 021-12 | 12 lt/min |
| 015-6 | 6,0 lt/min | 210-0 | Da forare/
To be drilled |
| 016-7 | 7,0 lt/min | | |

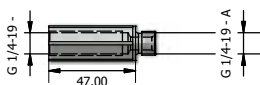

R8244051 C-MF-VSC01

Corpo MF G 1/4" per montaggio in linea VSC01*
MF body for VSC01* in-line mount

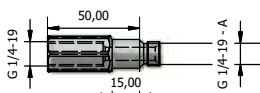

R8244052 C-MF-VSC01-S

Corpo speciale MF G 1/4" per montaggio in linea VSC01*
Special MF G 1/4" body for in-line mounting VSC01*

Corpo in linea tornito per montaggio sulle bocche di scarico del corpo centrale
In line turned body for in-tank mount on return ports below central manifold

10 Elettrovalvole a cartuccia e accessori

Solenoid cartridge valves and accessories

R9065051 MDV30E

Elettrovalvola N.C. 2 vie a doppia tenuta SAE08 con emergenza SAE08 2 way double locking N.C. solenoid valve with emergency

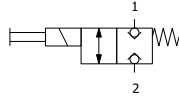
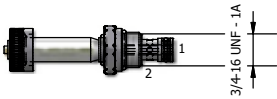

Pressione massima 210 bar
Max pressure 210 bar

Portata massima 15 lt/min
Max flow 15 lt/min

Filtraggio 25 micron
Filtering 25 micron

Coppia di serraggio 47 Nm
Tightening torque 47 Nm

* Utilizzabile solo con bobine in C.C. o RAC con connettore raddrizzatore

* To be used only with DC coils or RAC type coils and rectified connectors

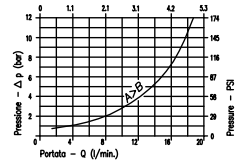

R9065101 MSV30

Elettrovalvola a tenuta N.C. 2 vie SAE08 SAE08 2 way poppet style N.C. solenoid valve

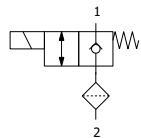
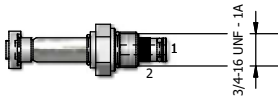

Pressione massima 300 bar
Max pressure 300 bar

Portata massima 20 lt/min
Max flow 20 lt/min

Filtraggio 25 micron
Filtering 25 micron

Coppia di serraggio 47 Nm
Tightening torque 47 Nm

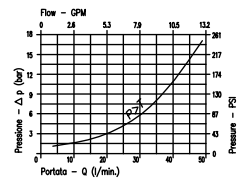

R9065102 MSV30E

Elettrovalvola a tenuta N.C. 2 vie a SAE08 con emergenza SAE08 2 way poppet style N.C. solenoid valve with emergency

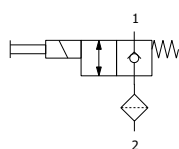
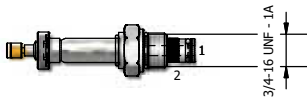

Pressione massima 300 bar
Max pressure 300 bar

Portata massima 20 lt/min
Max flow 20 lt/min

Filtraggio 25 micron
Filtering 25 micron

Coppia di serraggio 47 Nm
Tightening torque 47 Nm

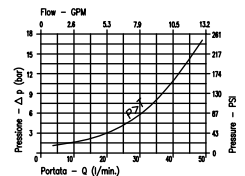

R9065103 MSV31

Elettrovalvola a tenuta N.A. 2 vie a SAE08 * SAE08 2 way poppet style N.O. solenoid valve *

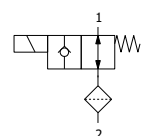
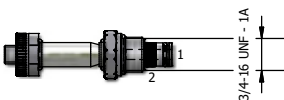

Pressione massima 210 bar**
Max pressure 210 bar**

Portata massima 20 lt/min
Max flow 20 lt/min

Filtraggio 25 micron
Filtering 25 micron

Coppia di serraggio 47 Nm
Tightening torque 47 Nm

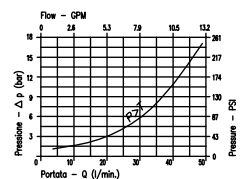

* Utilizzabile solo con bobine in C.C. o RAC con connettore raddrizzatore

* To be used only with DC coils or RAC type coils and rectified connectors

** 300 bar con bobine speciali da 32VA

** 300 bar with special 32VA coils

R9065104 MSV31E

Elettrovalvola a tenuta N.A. 2 vie a SAE08 con emergenza * SAE08 2 way poppet style N.O. solenoid valve with emergency *

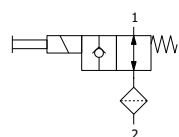
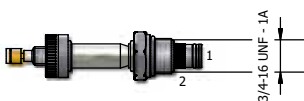

Pressione massima 210 bar**
Max pressure 210 bar**

Portata massima 20 lt/min
Max flow 20 lt/min

Filtraggio 25 micron
Filtering 25 micron

Coppia di serraggio 47 Nm
Tightening torque 47 Nm

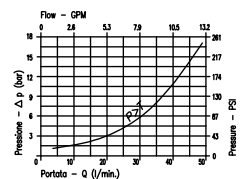

* Utilizzabile solo con bobine in C.C. o RAC con connettore raddrizzatore

* To be used only with DC coils or RAC type coils and rectified connectors

** 300 bar con bobine speciali da 32VA

** 300 bar with special 32VA coils

10 Elettrovalvole a cartuccia e accessori

Solenoid cartridge valves and accessories

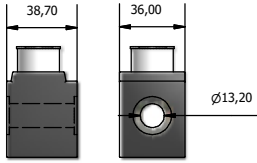

R9134002 COIL-12DC-D

Fattore di servizio ED100%
Duty ED100%

Temp.max di lavoro 125°C
Max working temp. 125°C

Grado di protezione IP54 secondo IEC144, IP56 con l'impiego di connettore DIN con le opportune guarnizioni
Protection degree IP54 according to IEC144, IP56 using a DIN connector with appropriate seals

Bobina 12V DC 12V DC Coil

Classe di isolamento H
Insulation class H

Max +/-10% tensione nominale
Max +/-10% nominal voltage

Tensione di alimentazione 12V C.C.
Supply voltage 12V DC

Tensione di alimentazione 12V C.C.
Supply voltage 12V DC

Temperatura ambiente -20 / + 50
Temperature -20 / + 50

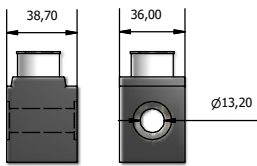

R9134052 COIL-24DC-D

Fattore di servizio ED100%
Duty ED100%

Temp.max di lavoro 125°C
Max working temp. 125°C

Grado di protezione IP54 secondo IEC144, IP56 con l'impiego di connettore DIN con le opportune guarnizioni
Protection degree IP54 according to IEC144, IP56 using a DIN connector with appropriate seals

Bobina 24V DC 24V DC Coil

Classe di isolamento H
Insulation class H

Max +/-10% tensione nominale
Max +/-10% nominal voltage

Tensione di alimentazione 12V C.C.
Supply voltage 12V DC

Potenza assorbita 22W
Power consumption 22W

Temperatura ambiente -20 / + 50
Temperature -20 / + 50

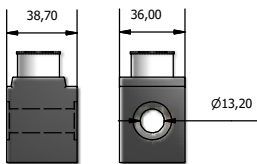

R9134100 COIL-48DC-D

Fattore di servizio ED100%
Duty ED100%

Temp.max di lavoro 125°C
Max working temp. 125°C

Grado di protezione IP54 secondo IEC144, IP56 con l'impiego di connettore DIN con le opportune guarnizioni
Protection degree IP54 according to IEC144, IP56 using a DIN connector with appropriate seals

Bobina 48V DC 48V DC Coil

Classe di isolamento H
Insulation class H

Max +/-10% tensione nominale
Max +/-10% nominal voltage

Tensione di alimentazione 48V C.C.
Supply voltage 12V DC

Potenza assorbita 22W
Power consumption 22W

Temperatura ambiente -20 / + 50
Temperature -20 / + 50

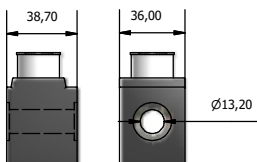

R9134200 COIL-110RAC-D

Fattore di servizio ED100%
Duty ED100%

Temp.max di lavoro 125°C
Max working temp. 125°C

Utilizzare questa bobina esclusivamente con connettori raddrizzatori K10, K20, K15
Use this coil only with rectified connectors K10, K20, K15

Grado di protezione IP54 secondo IEC144, IP56 con l'impiego di connettore DIN con le opportune guarnizioni
Protection degree IP54 according to IEC144, IP56 using a DIN connector with appropriate seals

Bobina 110V RAC 110V RAC Coil

Classe di isolamento H
Insulation class H

Max +/-10% tensione nominale
Max +/-10% nominal voltage

Tensione di alimentazione 110V raddrizzata
Supply voltage 110V rectified

Potenza assorbita 22W
Power consumption 22W

Temperatura ambiente -20 / + 50
Temperature -20 / + 50

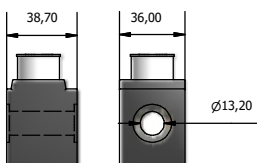

R9134251 COIL-220RAC-D

Fattore di servizio ED100%
Duty ED100%

Temp.max di lavoro 125°C
Max working temp. 125°C

Utilizzare questa bobina esclusivamente con connettori raddrizzatori K11, K21, K16
Use this coil only with rectified connectors K11, K21, K16

Grado di protezione IP54 secondo IEC144, IP56 con l'impiego di connettore DIN con le opportune guarnizioni
Protection degree IP54 according to IEC144, IP56 using a DIN connector with appropriate seals

Bobina 220V RAC 220V RAC Coil

Classe di isolamento H
Insulation class H

Max +/-10% tensione nominale
Max +/-10% nominal voltage

Tensione di alimentazione 220V raddrizzata
Supply voltage 220V rectified

Potenza assorbita 22W
Power consumption 22W

Temperatura ambiente -20 / + 50
Temperature -20 / + 50

10 Elettrovalvole a cartuccia e accessori

Solenoid cartridge valves and accessories

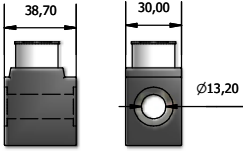

R9134256

COIL-220/50-ED100%-H

Fattore di servizio ED100% Classe di isolamento H
 Duty ED100% Insulation class H
 Temp.max di lavoro 125°C Max +/-10% tensione nominale
 Max working temp. 125°C Max +/-10% nominal voltage

Tensione di alimentazione 220V AC 50Hz
 Supply voltage 220V AC 50Hz

Potenza assorbita 20VA
 Power consumption 20VA

Temperatura ambiente -20 / + 50
 Temperature -20 / + 50

Grado di protezione IP54 secondo IEC144, IP56 con l'impiego di connettore DIN con le opportune guarnizioni
 Protection degree IP54 according to IEC144, IP56 using a DIN connector with appropriate seals

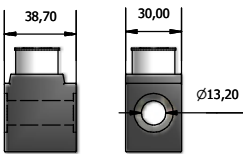

R9134257

COIL-115/50-ED100%-H

Fattore di servizio ED100% Classe di isolamento H
 Duty ED100% Insulation class H
 Temp.max di lavoro 125°C Max +/-10% tensione nominale
 Max working temp. 125°C Max +/-10% nominal voltage

Tensione di alimentazione 115V AC 50Hz
 Supply voltage 115V AC 50Hz

Potenza assorbita 20VA
 Power consumption 20VA

Temperatura ambiente -20 / + 50
 Temperature -20 / + 50

Grado di protezione IP54 secondo IEC144, IP56 con l'impiego di connettore DIN con le opportune guarnizioni
 Protection degree IP54 according to IEC144, IP56 using a DIN connector with appropriate seals

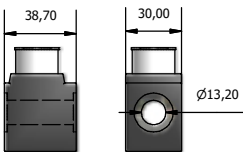

R9134258

COIL-24/50-ED100%-H

Fattore di servizio ED100% Classe di isolamento H
 Duty ED100% Insulation class H
 Temp.max di lavoro 125°C Max +/-10% tensione nominale
 Max working temp. 125°C Max +/-10% nominal voltage

Tensione di alimentazione 24V AC 50Hz
 Supply voltage 24V AC 50Hz

Potenza assorbita 20VA
 Power consumption 20VA

Temperatura ambiente -20 / + 50
 Temperature -20 / + 50

Grado di protezione IP54 secondo IEC144, IP56 con l'impiego di connettore DIN con le opportune guarnizioni
 Protection degree IP54 according to IEC144, IP56 using a DIN connector with appropriate seals

Connettori Elettrici DIN 43650-A Nero pg11

Electric Connectors DIN 43650-A Black pg11



Connettore Nero STANDARD 3 poli
 STANDARD Black Connector 3 pins

	12V	24V	48V	110V	230V
Connettore Nero STANDARD 3 poli	//	//	R9242001 K0	//	//

Connettore con LED e VDR
 Connector with LED and VDR

Connettore con LED e VDR	R9242100 K7	R9242101 K8	R9242102 K9	R9242103 K10	R9242104 K11
--------------------------	----------------	----------------	----------------	-----------------	-----------------



Connettore con RADDRIZZATORE e VDR
 Connector with RECTIFIER and VDR

Connettore con RADDRIZZATORE e VDR	R9242200 K17	R9242201 K18	R9242202 K19	R9242202 K20	R9242204 K21
------------------------------------	-----------------	-----------------	-----------------	-----------------	-----------------

Connettore con RADDRIZZATORE, VDR e LED
 Connector with RECTIFIER, VDR and LED

Connettore con RADDRIZZATORE, VDR e LED	R9242150 K12	R9242151 K13	R9242152 K14	R9242153 K15	R9242154 K16
---	-----------------	-----------------	-----------------	-----------------	-----------------

11 Manometri, pressostati e accessori

Pressure gauges, pressure switches and accessories

R9300*
MGP63/*****

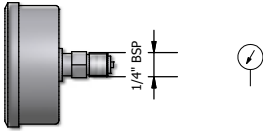

Serie manometri INOX D.63mm a bagno di glicerina con attacco posteriore DIN16288 G1/4"
D.63mm stainless steel glicerine pressure gauge series with backside DIN16288 G1/4" connection

R9300009	MGP63/006	Scala 10 bar / 10 bar scale
R9300008	MGP63/016	Scala 16 bar / 16 bar scale
R9300001	MGP63/025	Scala 25 bar / 25 bar scale
R9300002	MGP63/060	Scala 60 bar / 60 bar scale
R9300003	MGP63/100	Scala 100 bar / 100 bar scale
R9300004	MGP63/160	Scala 160 bar / 160 bar scale
R9300005	MGP63/250	Scala 250 bar / 250 bar scale
R9300006	MGP63/400	Scala 400 bar / 400 bar scale

R9300*
MGR63/*****

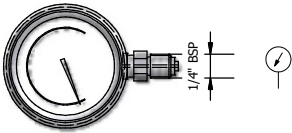

Serie manometri INOX D.63mm a bagno di glicerina con attacco radiale DIN16288 G1/4"
D.63mm stainless steel glicerine pressure gauge series with radial DIN16288 G1/4" connection

R9300100	MGR63/006	Scala 10 bar / 10 bar scale
R9300101	MGR63/010	Scala 10 bar / 10 bar scale
R9300102	MGR63/016	Scala 16 bar / 16 bar scale
R9300103	MGR63/060	Scala 60 bar / 60 bar scale
R9300104	MGR63/100	Scala 100 bar / 100 bar scale
R9300105	MGR63/160	Scala 160 bar / 160 bar scale
R9300106	MGR63/250	Scala 250 bar / 250 bar scale
R9300107	MGR63/400	Scala 400 bar / 400 bar scale
R9300108	MGR63/600	Scala 600 bar / 600 bar scale

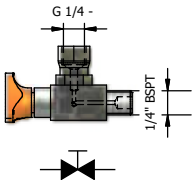

**R9222001
E014**
Valvola di esclusione manometro con connessione G1/4" conico volantino e attacco manometro a 90° DIN16288 1/4"

Pressure gauge isolator with G1/4" conical connection knob and 90° gauge connection according to DIN16288 1/4"

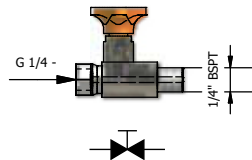

**R9222002
E015**
Valvola di esclusione manometro con connessione G1/4" conico volantino e attacco manometro in linea DIN16288 1/4"

Pressure gauge isolator with G1/4" conical connection knob and in-line gauge connection according to DIN16288 1/4"

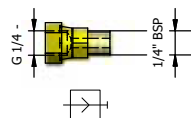

**R9222003
E017**
Attacco manometro con connessione G1/4" conica e attacco manometro DIN16288 1/4"

Pressure gauge fitting with G1/4" conical connection according to DIN16288 1/4"

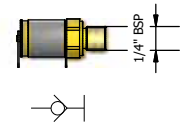

**R9222004
MPN140**
Preso di pressione con attacco G1/4" cilindrico e o-ring

Non-spill pressure port G1/4" connection with o-ring

12 Tappi SAE per corpo centrale e raccordi BSP

SAE plugs for central manifold and BSP fittings

Tappi funzione Metrici e SAE

Metric and SAE function plugs

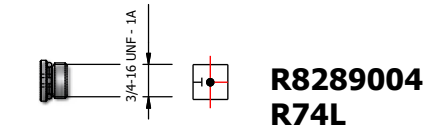

R8289004
R74L

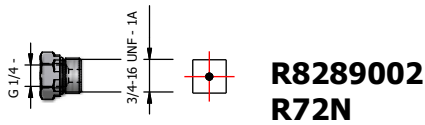

R8289002
R72N

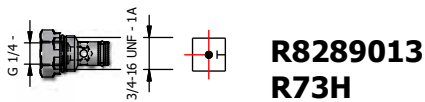

R8289013
R73H

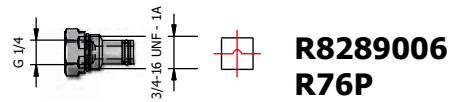

R8289006
R76P

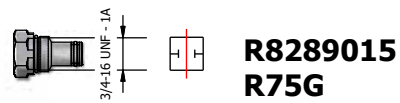

R8289015
R75G

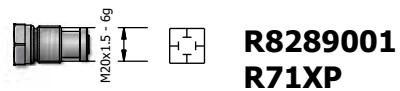

R8289001
R71XP

Raccordi BSP

BSP fittings

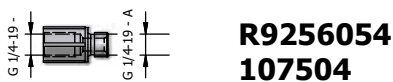

R9256054
107504



R9218054
300504



R9289004
107604

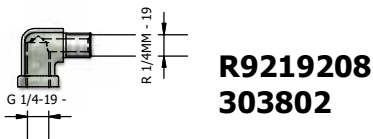

R9219208
303802

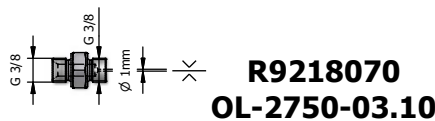

R9218070
OL-2750-03.10

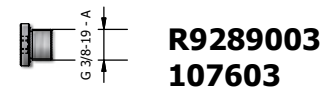

R9289003
107603

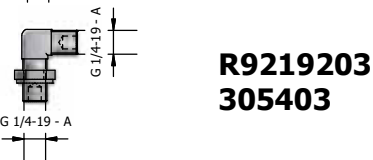

R9219203
305403

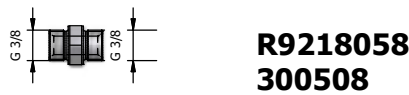

R9218058
300508

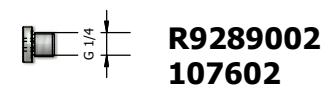

R9289002
107602

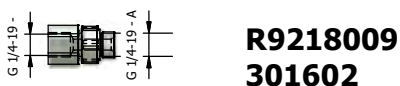

R9218009
301602

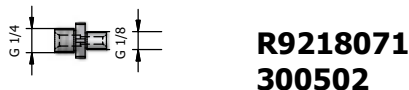

R9218071
300502

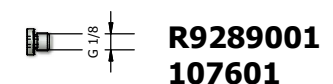

R9289001
107601

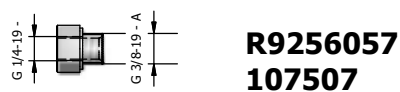

R9256057
107507

13 Pompe ad ingranaggi

Gear pumps

Versione Standard

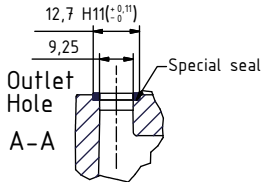
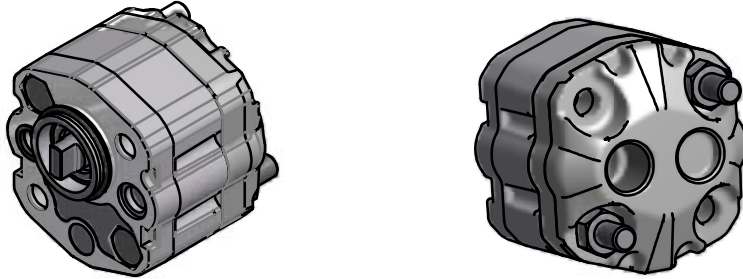

La pompa rappresentata ha rotazione sinistra
 The pump represented has anti-clockwise rotation

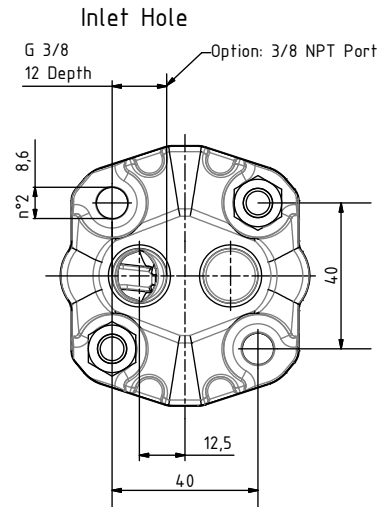
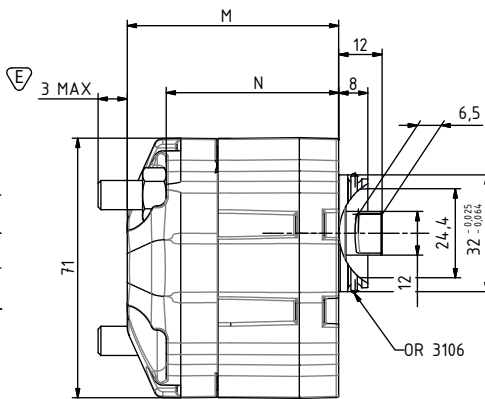
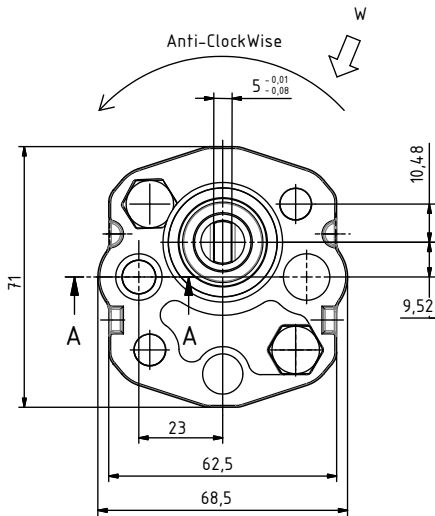

PER IL FISSAGGIO DELLA POMPA UTILIZZARE VITI M8 - 8.8
 Coppia di serraggio 23,0 ± 25.0 Nm

TO FIX THE PUMP USE BOLTS M8 – 8.8
 23,0 ± 25.0 Nm screw tightening torque M8

13 Pompe ad ingranaggi

Gear pumps

Codice di ordinazione Ordering code	Cilindrata Displacement (cc/rev)	Portata a Flow at 1500 rpm (l/min)	M mm	N mm	P1 (bar)	P2 (bar)	P3 (bar)	Velocità max Max speed (rpm)
R9026030 G108-OEM	0,8	1,2	47,0	36,3	210	230	250	6000
R9026036 G111-OEM	1,1	1,6	47,5	36,8	210	230	250	6000
R9026040 G113-OEM	1,3	2,0	48,5	37,8	210	230	250	6000
R9026032 G116-OEM	1,6	2,4	49,5	38,8	210	230	250	6000
R9026031 G120-OEM	2,1	3,2	51,0	40,3	210	230	250	6000
R9026037 G126-OEM	2,6	4,0	53,0	42,3	210	230	250	6000
R9026035 G132-OEM	3,2	4,8	54,5	43,8	190	210	230	5000
R9026029 G137-OEM	3,7	5,6	56,5	45,8	190	210	230	4500
R9026033 G142-OEM	4,2	6,4	58,0	47,3	190	190	210	4000
R9026038 G148-OEM	4,8	7,2	60,0	49,3	170	190	210	3500
R9026034 G158-OEM	5,8	8,7	63,5	52,8	170	190	210	3000
R9026039 G180-OEM	8,0	11,9	100,0	88,0	170	190	210	2100

P1 Max pressione di lavoro in continuo
 P2 Max pressione di lavoro intermittente 30 sec
 P3 Max pressione di picco 3 sec

P1 Max continuous pressure
 P2 Max intermittent max pressure 30 sec
 P3 Max peak pressure 3 sec

Si raccomanda l'uso di fluidi specifici per circuiti idraulici a base d'olio minerale, con buone caratteristiche antiusura e antischiuma, con proprietà di rapida disareazione, antiossidanti, anticorrosione.

Use specific mineral oil based hydraulic fluids having good anti-wear, anti-foaming (rapid de-aeration), antioxidant, anti-corrosion and lubricating properties.

La temperatura del fluido durante il funzionamento della pompa deve essere compreso tra -15°C ÷ +80°C

Pump operating temperature should range between: -15°C ÷ +80°C

14 Filtri e componenti per aspirazione e scarico

Filters, suction and return line components

Filtri in aspirazione

Suction filters

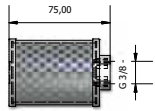

R9176005
C3414

Superficie filtrante 200cm²
Filtering surface 200cm²

Elemento filtrante 90μ Repts FeZN
Filtering element 90μ Repts FeZN

Portata 16lt/min
Flow 16lt/min

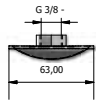

R9176004
C3415

Superficie filtrante 30cm²
Filtering surface 30cm²

Elemento filtrante 90μ Repts FeZN
Filtering element 90μ Repts FeZN

Portata 10lt/min
Flow 10lt/min

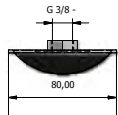

R9176002
C3412

Superficie filtrante 200cm²
Filtering surface 200cm²

Elemento filtrante 90μ Repts FeZN
Filtering element 90μ Repts FeZN

Portata 14lt/min
Flow 14lt/min

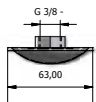

R9176003
C3413

Superficie filtrante 45cm²
Filtering surface 45cm²

Elemento filtrante 90μ Repts FeZN
Filtering element 90μ Repts FeZN

Portata 12lt/min
Flow 12lt/min



R9176007
C3419

Superficie filtrante 34cm²
Filtering surface 34cm²

Elemento filtrante 200μ Repts FeZN
Filtering element 200μ Repts FeZN

Portata 8lt/min
Flow 8lt/min

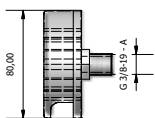

R9176001
C3411

Superficie filtrante 100cm²
Filtering surface 100cm²

Elemento filtrante 90μ Repts FeZN
Filtering element 90μ Repts FeZN

Portata 14lt/min
Flow 14lt/min

Filtri sul ritorno

Return line filters

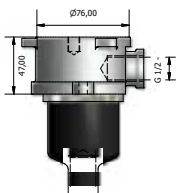

R9176006
C3418

Superficie filtrante XXcm²
Filtering surface XXcm²

Elemento filtrante 10μ Repts FeZN
Filtering element 10μ Repts FeZN

Portata XXlt/min
Flow XXlt/min

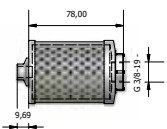

R9176050
C3417

Superficie filtrante 30cm²
Filtering surface 30cm²

Elemento filtrante 90μ Repts FeZN
Filtering element 90μ Repts FeZN

Portata 10lt/min
Flow 10lt/min

14 Filtri e componenti per aspirazione e scarico

Filters, suction and return line components

Descrizione

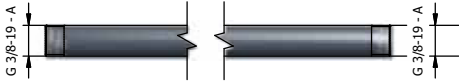

R9304***
EPD60R 3/8 mm

Serie tubi di aspirazione G3/8" in EPD
Series of EPD G3/8" suction hoses

Lunghezze disponibili

Available lengths

(Disponibili solo in box da 100 pezzi)
(Available only in box of 100 pieces)

***	001	002	003	004	005	006	007	008	009	010
mm	25	40	60	80	100	130	160	180	200	235

***	011	012	013	014	015
mm	250	300	350	500	400

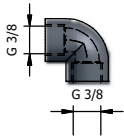

R9223001
E602

Raccordo a G3/8" in PVC 90° per kit aspirazione orizzontale
90° PVC fitting for horizontal suction kit

(Disponibili solo in box da 100 pezzi)
(Available only in box of 100 pieces)



R9305***
PVC 1/4 mm

Serie tubi di scarico G1/4" in PVC
Series of PVC G1/4" return hoses

Lunghezze disponibili

Available lengths

(Disponibili solo in box da 100 pezzi)
(Available only in box of 100 pieces)

***	001	002	003	004	005	006	007	008	009	010
mm	115	125	210	235	295	300	320	370	450	90

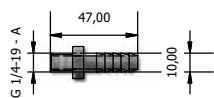

R9223003
PGD12X10

Portagomma G1/4" T.10 mm per montaggio tubo in rilsan 12x10
Barbed fitting G1/4" T.10 mm for return rilsan hose 12x10

(Disponibili solo in box da 100 pezzi)
(Available only in box of 100 pieces)

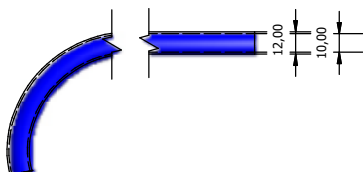

R9289104
TR12X10

Tubo rilsan per linee di scarico antischiuma nel serbatoio
Rilsan hose for in-tank anti foam return lines

(Disponibili solo in matasse da 25 metri)
(Available only in coils of 25 meters)

15 Blocchi valvole SAE, Cetop3 e blocchi accessori

SAE ad Cetop3 valve blocks and accessory blocks

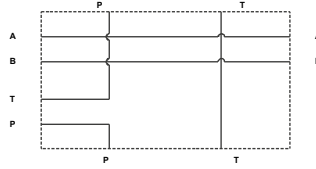
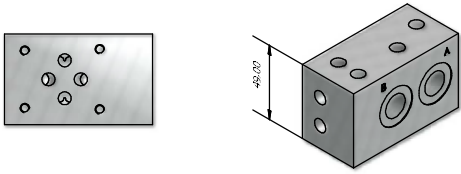

R8132003
E003

Blocco in serie CETOP 3 - uscite 3/8" BSPP posteriori
CETOP 3 series block- 3/8" BSPP rear ports

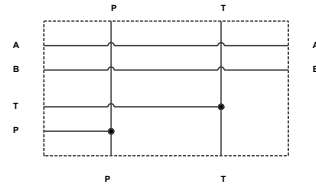
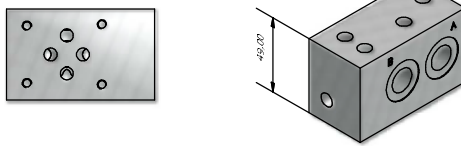

R8132001
E001

Blocco parallelo CETOP 3 - uscite 3/8" BSPP posteriori
CETOP 3 parallel block-3/8" BSPP rear ports

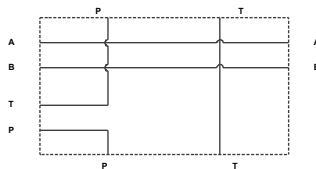
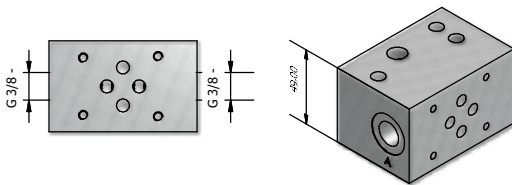

R8132009
E011

Blocco in serie CETOP 3 - uscite 3/8" BSPP laterali
CETOP 3 series block- 3/8" BSPP lateral ports

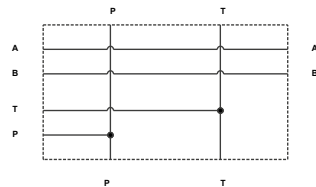
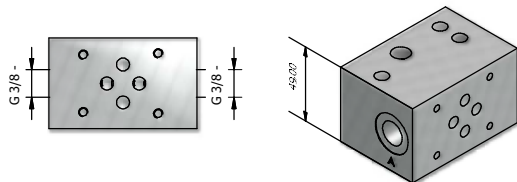

R8132008
E010

Blocco parallelo CETOP 3 - uscite 3/8" BSPP laterali
CETOP 3 parallel block-3/8" BSPP lateral ports

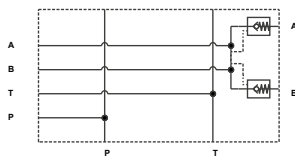
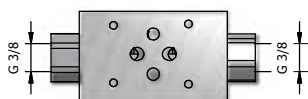

R8132113
E101

Piastra CETOP 3 con valvola di ritegno pilotata su A e B
CETOP 3 manifold with piloted check valve on A and B

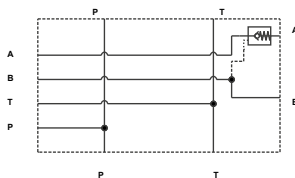
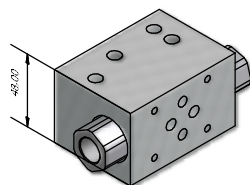

R8132114
E102

Piastra CETOP 3 con valvola di ritegno pilotata su A
CETOP 3 manifold with piloted check valve on A

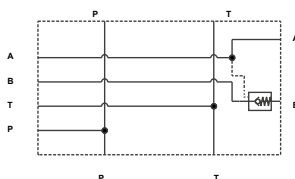

R8132115
E103

Piastra CETOP 3 con valvola di ritegno pilotata su B
CETOP 3 manifold with piloted check valve on B

15 Blocchi valvole SAE, Cetop3 e blocchi accessori

SAE ad Cetop3 valve blocks and accessory blocks

R8132004

E004

Distanziale spessore 30 mm
30 mm height spacer subplate

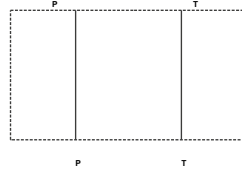
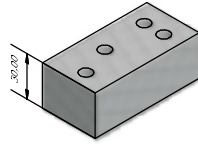

R8132007

E007

Blocco modulare distanziale con uscite
addizionali "P" e "T" 3/8" BSPP laterali
Modular spacer block with "P" & "T"
additional lateral 3/8" BSPP outlets

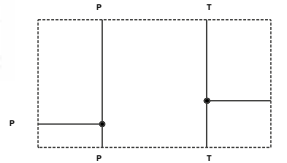
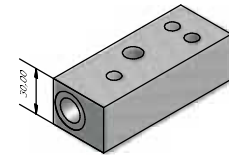
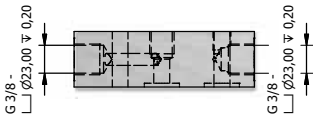

R8132005

E005

Blocco collettore per rotazione 90° con
connessione aggiuntiva «P» 1/4" BSP
90° rotation manifold with additional
1/4" BSP «P» port

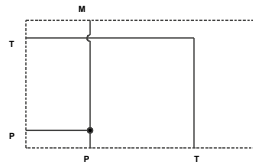
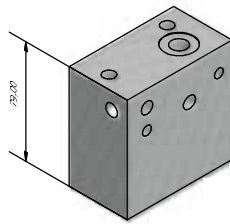
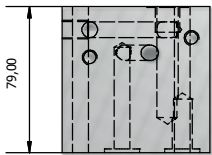

R8132010

E030

Piastra per valvole MSV e MDV
Block for MSV or MDV valve

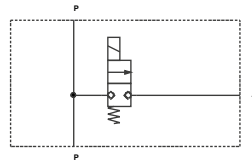
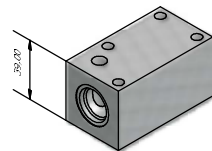
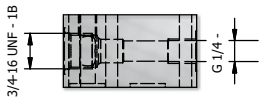

R8132011

E031

Piastra per valvole MSV e MDV con ritorno
(fornita senza valvole)
Block for MSV or MDV valve with return line
(supplied without valves)

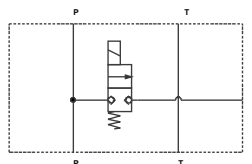
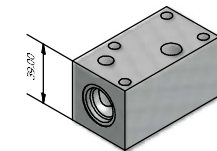
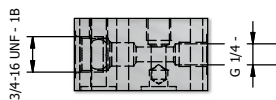

R8132021

VSC-3/4-16 1/4

Corpo per cartucce in linea MSV +
VSC01 3/4"-16 UNF uscite 1/4" BSP
(fornita senza valvole)

MSV + VSC01 3/4"-16 UNF outlets 1/4"
BSP in-line manifold (supplied without valves)

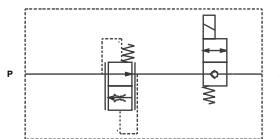
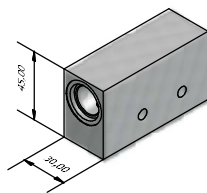
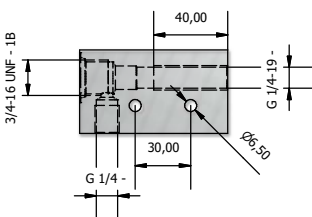

15 Blocchi valvole SAE, Cetop3 e blocchi accessori

SAE ad Cetop3 valve blocks and accessory blocks

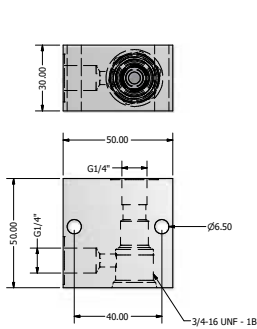

R8132012
BFC-3/4-16 1/4

Corpo per montaggio in linea cartucce a 2 vie 3/4"-16 UNF (SE08) (uscite 1/4" BSP)

In line assembly manifold for 2 way 3/4" - 16 UNF (SAE08) cartridge valves (1/4" BSP outlet ports)

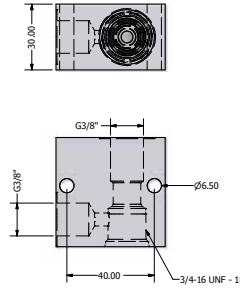

R8132013
BFC-3/4-16 3/8

Corpo per montaggio in linea cartucce a 2 vie 3/4"-16 UNF (SE08) (uscite 3/8" BSP)

In line assembly manifold for 2 way 3/4" - 16 UNF (SAE08) cartridge valves (3/8" BSP outlet ports)

16 Pompe a mano di emergenza modulari e a cartuccia

Modular and cartridge manual emergency pumps

R6021001
PM88

Pompa di emergenza manuale modulare con cilindrata 8,8 cc *

Modular emergency hand pump 8,8 cc displacement *

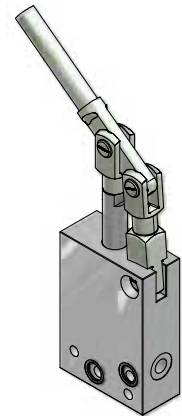
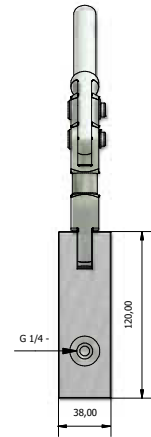
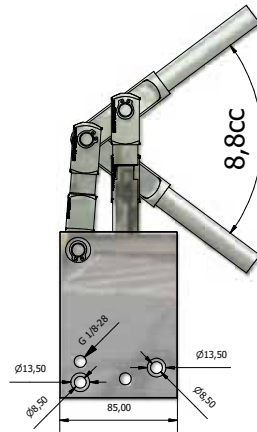
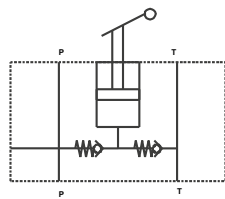

* La pompa può essere montata in posizione intermedia, alla fine o all'inizio di una serie di blocchi modulari. Viene fornita in kit con prolunga di 48 cm e il meccanismo di azionamento può essere capovolto scambiando la posizione di montaggio dei perni e della leva.

* The pump can be mounted in between, at the end or before a stack of other modular manifolds. It is supplied in kit with a 48 cm handle and the handle actuating mechanism can be reversed by switching the lever fixing pins and lever position.

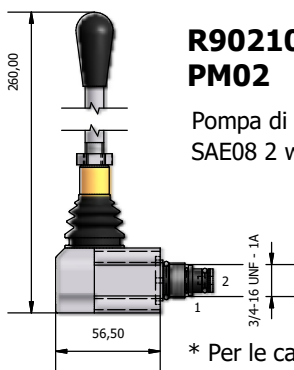
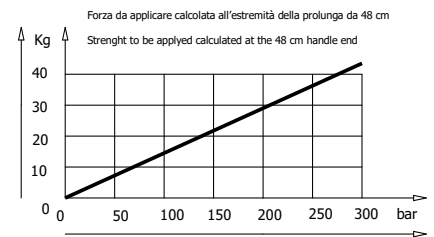

R9021001
PM02

Pompa di emergenza manuale da 2,00 cc a cartuccia SAE08 2 vie *

SAE08 2 way cartridge emergency hand pump 2,00 cc *

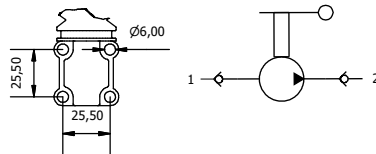

* Per le cavità in cui può essere montata vedere sezione 5
* See section 5 to see the cavities in which it can be mounted

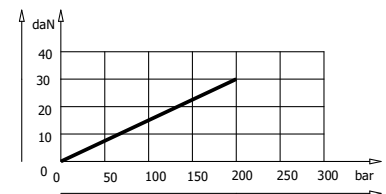

17 Serbatoi in plastica (PE)

Plastic (PE) tanks

5PL*

Serbatoio in PE da 5 litri di capacità montaggio orizzontale (**5PLH**) o verticale (**5PLV**)
 PE tank 5 liters capacity horizontal (**5PLH**) or vertical (**5PLV**) mounting

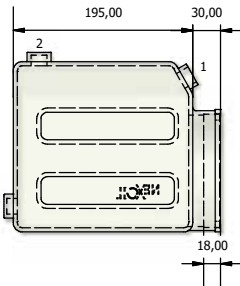
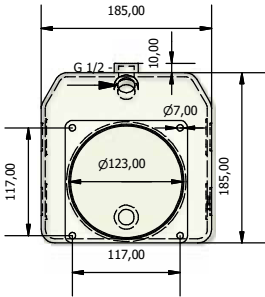

Fornito in kit con tappo di carico
 Supplied with plug kit
 Temperatura di impiego -10°C + 70°C
 Working temperature -10°C + 70°C
 Predisposizione foro liscio o filettato in 3 posizioni,
 foro standard: G1/2" Nr.1
 Predisposition smothed or threaded hole in 3 position,
 standard hole: G1/2" Nr.1

8PL*

Serbatoio in PE da 8 litri di capacità montaggio orizzontale (**8PLH**) o verticale (**8PLV**)
 PE tank 8 liters capacity horizontal (**8PLH**) or vertical (**8PLV**) mounting

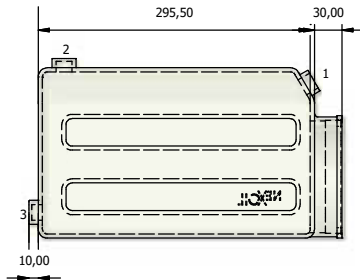
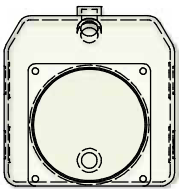

Fornito in kit con tappo di carico
 Supplied with plug kit
 Temperatura di impiego -10°C + 70°C
 Working temperature -10°C + 70°C
 Predisposizione foro liscio o filettato in 3 posizioni,
 foro standard: G1/2" Nr.1
 Predisposition smothed or threaded hole in 3 position,
 standard hole: G1/2" Nr.1

12PL*

Serbatoio in PE da 12 litri di capacità montaggio orizzontale (**12PLH**) o verticale (**12PLV**)
 PE tank 12 liters capacity horizontal (**12PLH**) or vertical (**12PLV**) mounting

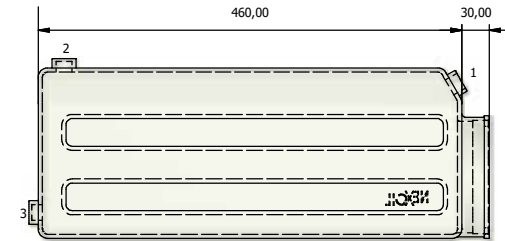
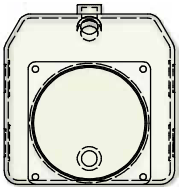

Fornito in kit con tappo di carico
 Supplied with plug kit
 Temperatura di impiego -10°C + 70°C
 Working temperature -10°C + 70°C
 Predisposizione foro liscio o filettato in 3 posizioni,
 foro standard: G1/2" Nr.1
 Predisposition smothed or threaded hole in 3 position,
 standard hole: G1/2" Nr.1

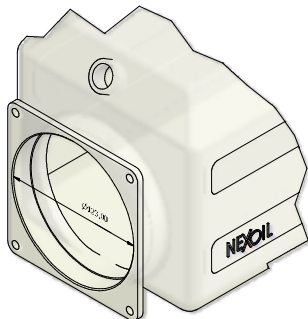

R9289154
TRM-12

Tappo con filtro e sfiato G1/2"
 G1/2" breather and filter filling plug



R9289103
TSG-12

Tappo di scarico G1/2" (opzionale)
 G1/2" unloading plug (optional)

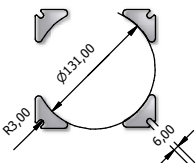

R7115013
PLT4XR

Kit opzionale 4 piastine di rinforzo in acciaio zincato per serbatoi in plastica
 Optional reinforcement 4 zinc plated steel brackets kit for plastic tanks

18 Serbatoi cilindrici in acciaio

Cilindrical steel tanks

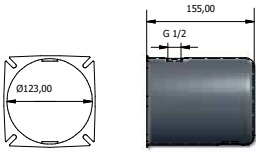

1,5S*

Serbatoio cilindrico in acciaio da 1,5 litri orizzontale (**1,5SH**) o verticale (**1,5SV**) con tappi e raccordi
Cylindrical steel tank 2,5 liters horizontal (**1,5SH**) or vertical (**1,5SV**) with plugs and fittings



R9289154 (TRM-12)

Tappo di carico G1/2"
Filling plug G1/2"

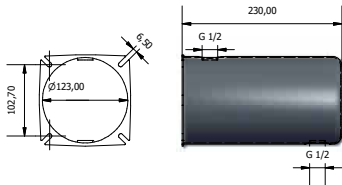

2,5S*

Serbatoio cilindrico in acciaio da 2,5 litri orizzontale (**2,5SH**) o verticale (**2,5SV**) con tappi e raccordi
Cylindrical steel tank 2,5 liters horizontal (**1,5SH**) or vertical (**1,5SV**) with plugs and fittings



R9289103 (TSG-12)

Tappo di scarico G1/2"
Unloading plug G1/2"

R9223001 (E602)

Curva MF G1/2" 90° per serbatoi verticali
90° MF G1/2" elbow for vertical tanks

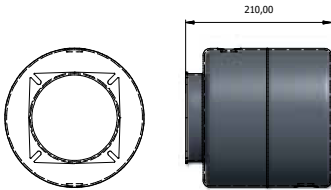
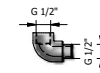

5S*

Serbatoio cilindrico in acciaio da 5 litri orizzontale (**5SH**) o verticale (**5SV**)
Cylindrical steel tank 5 liters horizontal (**5SH**) or vertical (**5SV**)
(Kit completo di tappi di carico scarico e anello di tenuta)
(Complete kit with filling and unloading plugs and O-ring)

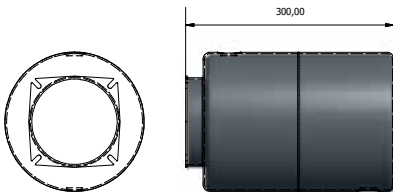

8S*

Serbatoio cilindrico in acciaio da 8 litri orizzontale (**8SH**) o verticale (**8SV**)
Cylindrical steel tank 8 liters horizontal (**8SH**) or vertical (**8SV**)
(Kit completo di tappi di carico scarico e anello di tenuta)
(Complete kit with filling and unloading plugs and O-ring)

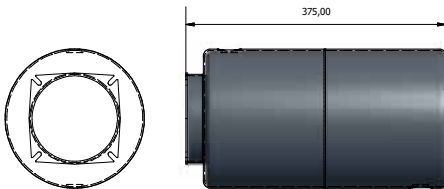

10S*

Serbatoio cilindrico in acciaio da 10 litri orizzontale (**10SH**) o verticale (**10SV**)
Cylindrical steel tank 10 liters horizontal (**10SH**) or vertical (**10SV**)
(Kit completo di tappi di carico scarico e anello di tenuta)
(Complete kit with filling and unloading plugs and O-ring)

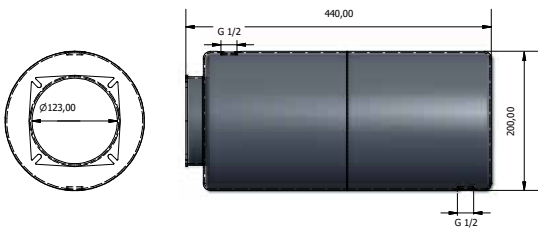

12S*

Serbatoio cilindrico in acciaio da 12 litri orizzontale (**12SH**) o verticale (**12SV**)
Cylindrical steel tank 12 liters horizontal (**12SH**) or vertical (**12SV**)
(Kit completo di tappi di carico scarico e anello di tenuta)
(Complete kit with filling and unloading plugs and O-ring)

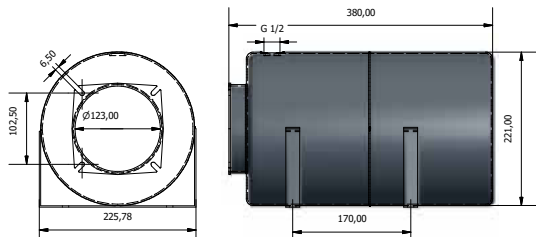

12C

Serbatoio cilindrico in acciaio da 12 litri con staffe di supporto
Cylindrical steel tank 12 liters capacity with support brackets
(Kit completo di tappo di carico e anello di tenuta per corpo centrale)
(Complete kit with filling plug and O-ring for central manifold)

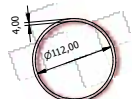

R9189008 OR112X4

O-ring speciale di tenuta fornito con i serbatoi D.200 mm e D.220 mm
Special sealing O-ring supplied with D.200 mm and D.220 mm tanks

19 Serbatoi rettangolari in acciaio con coperchio avvitato

Rectangular steel tanks with screw-on cover

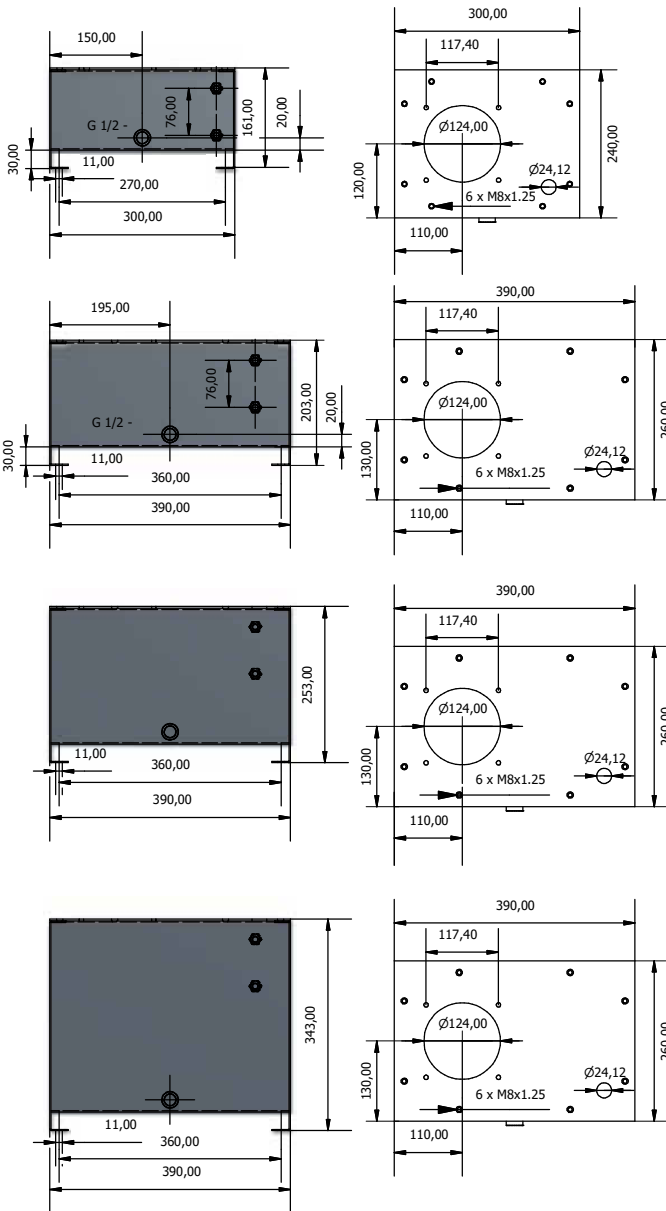

7LV

Serbatoio da 7 litri in acciaio rettangolare con coperchio
7 liters capacity rectangular tank with cover

(Completo di tappi di carico, scarico, guarnizioni e livello visivo)
 (Complete of filling and unloading plugs, visual oil level and seals)

15LV

Serbatoio da 15 litri in acciaio rettangolare con coperchio
15 liters capacity rectangular tank with cover

(Completo di tappi di carico, scarico, guarnizioni e livello visivo)
 (Complete of filling and unloading plugs, visual oil level and seals)

20LV

Serbatoio da 20 litri in acciaio rettangolare con coperchio
20 liters capacity rectangular tank with cover

(Completo di tappi di carico, scarico, guarnizioni e livello visivo)
 (Complete of filling and unloading plugs, visual oil level and seals)

30LV

Serbatoio da 30 litri in acciaio rettangolare con coperchio
30 liters capacity rectangular tank with cover

(Completo di tappi di carico, scarico, guarnizioni e livello visivo)
 (Complete of filling and unloading plugs, visual oil level and seals)

R9289155

TRM-34

Tappo di carico G3/4"
 Filling plug G3/4"

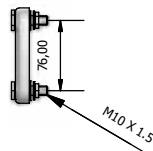

R9041001

SLV76

Indicatore visivo livello olio
 Visual oil level indicator

R9289103

TSG-12

Tappo di scarico G1/2"
 Unloading plug G1/2"

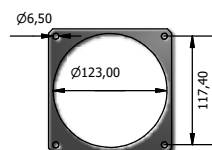

R8161001

SEAL01

Guarnizione per montaggio corpo centrale
 Central manifold mountig seal

20 Serbatoi rettangolari in acciaio con collare

Rectangular steel tanks with collar

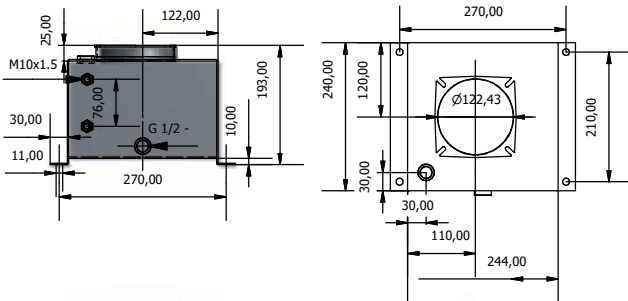

7LCV

Serbatoio in acciaio rettangolare con collare da 7 litri
7 liters capacity rectangular tank with collar

(Completo di tappo di scarico, tappo di carico e livello visivo)
 (Complete of unloading plug, filling plug and visual oil level)

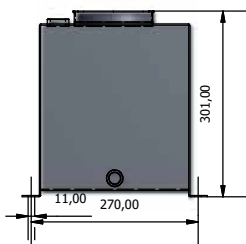

15LC

Serbatoio rettangolare in acciaio con collare da 15 litri
15 liters capacity rectangular tank with collar

(Con tappo di scarico e tappo di carico con astina di livello)
 (Complete of unloading plug and filling plug with oil level stick)

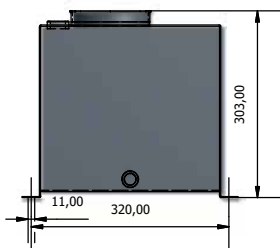
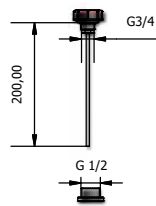

20LC

Serbatoio in acciaio rettangolare con collare da 20 litri
20 liters capacity rectangular tank with collar

(Con tappo di scarico e tappo di carico con astina di livello)
 (Complete of unloading plug and filling plug with oil level stick)

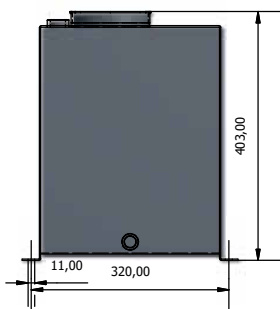
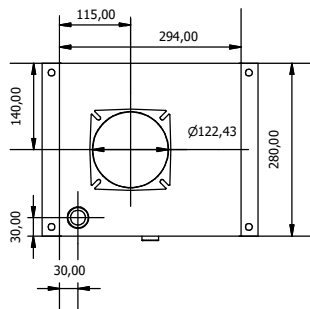

30LC

Serbatoio in acciaio rettangolare con collare da 30 litri
30 liters capacity rectangular tank with collar

(Con tappo di scarico e tappo di carico con astina di livello)
 (Complete of unloading plug and filling plug with oil level stick)

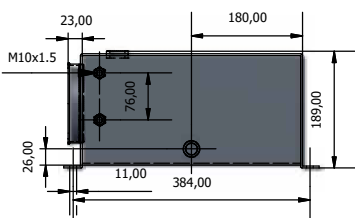
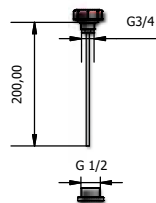

15E

Serbatoio in acciaio con collare orizzontale da 15 litri
15 liters capacity tank with horizontal collar

(Completo di tappo di scarico, tappo di carico e livello visivo)
 (Complete of unloading plug, filling plug and visual oil level)

R9289155

TRM-34

Tappo di carico G3/4"
 Filling plug G3/4"



R9041001

SLV76

Indicatore visivo livello olio
 Visual oil level indicator

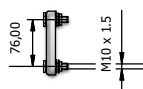

R9289103

TSG-12

Tappo di scarico G1/2"
 Unloading plug G1/2"



21 Accessori

Accessories

Descrizione

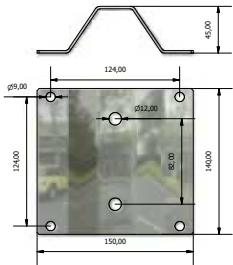

R8278003 F Piedino di supporto centrale in acciaio zincato
Zinc plated steel foot mounting support

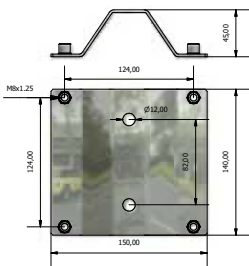

R8278004 F08-TL Piedino di supporto centrale in acciaio zincato con inseri filettati M8
Zinc plated steel foot mounting support with M8 threaded inserts

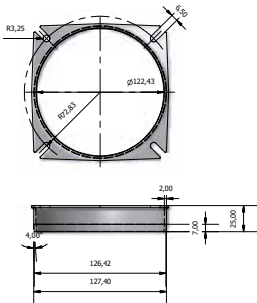

R8177101 R81 Collare in acciaio a saldare per realizzazione serbatoi a disegno
Weld-on steel collar for custom tanks

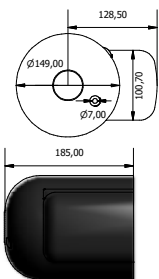

R9138001 F16 Protezione motore in C.C. D.112-115
D.112-115 DC motor protection cover



R8289101 D-CAP Sigillo antimanomissione valvola di massima VMDC35/**
Tampering prevention seal relief valve VMDC35/**

22 Valvole e accessori modulari Cetop3

Cetop3 modular valves and accessories

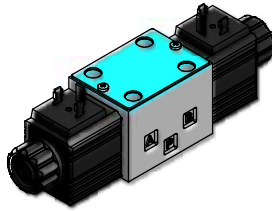
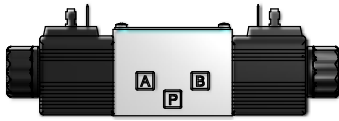

Elettrovalvola direzionale CETOP3 con bobine (1)
Directional solenoid CETOP3 valve with coils (1)

Versioni disponibili
Available version

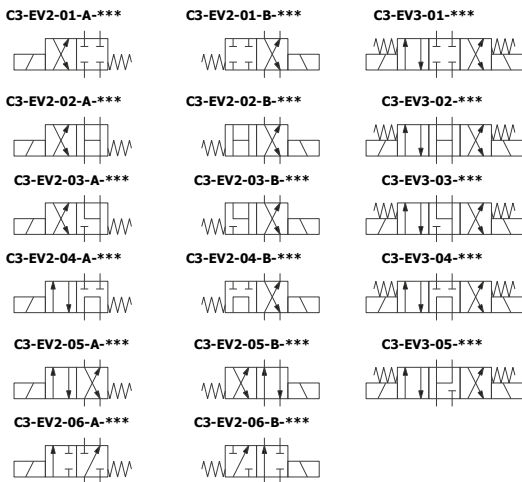

C3 - EV* - ** - * - ****

Numero di posizioni
 Valve positions number

N° riferimento schema idraulico
 Hydraulic scheme reference n°

Solenoide lato A o lato B (solo per valvole a 3 posizioni)
 A side or B side solenoid position (Only for 3 position valves)

Codice di riferimento tensione bobine
 Coil voltage reference code

- | | | | | | | |
|------------|------------|---------------|-------------|--|-------------|-------------|
| D12 | D24 | R110 | R230 | A24 | A110 | A230 |
| 12V CC | 24V CC | 110V | 230V | 24V 50Hz | 110V 50Hz | 230v 50Hz |
| 24V DC | 24V DC | (Raddrizzata) | | (1) Bobine standard per connettori DIN 43650-A | | |
| | | (Rectified) | | (1) Standard coils for DIN 43650-A connectors | | |

LIMITI DI IMPIEGO

Le curve delimitano i campi di funzionamento portata in funzione della pressione per le diverse esecuzioni dell'elettrovalvola. Le prove sono state eseguite secondo la norma ISO 6403, con tensione di alimentazione al 90% del valore nominale e con magneti a temperatura di regime. I valori indicati sono rilevati, con olio minerale viscosità 36 cSt a 50°C e filtrazione ISO 4406:1999 classe 18/16/13.

OPERATING LIMITS

The curves define the flow rate operating fields according to the valve pressure of the different versions. The values have been obtained according to ISO 6403 norm with solenoids at rated temperature and supplied with voltage equal to 90% of thenominal voltage. The value have been obtainedwith mineral oil, viscosity 36 cSt, temperature 50 °C and filtration according to ISO 4406:1999class 18/16/13.

PERDITE DI CARICO Δp-Q

(valori ottenuti con viscosità 36 cSt a 50 °C)

PRESSURE DROPS Δp-Q

(obtained with viscosity of 36 cSt at 50 °C)

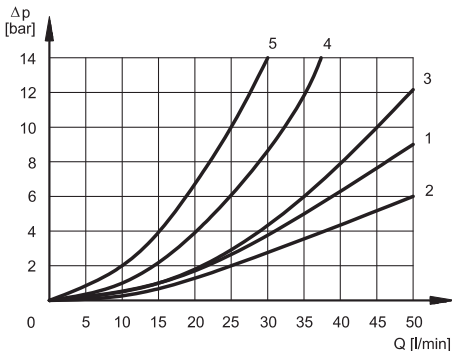

ELETTROVALVOLA COMMUTATA
ENERGIZED VALVE

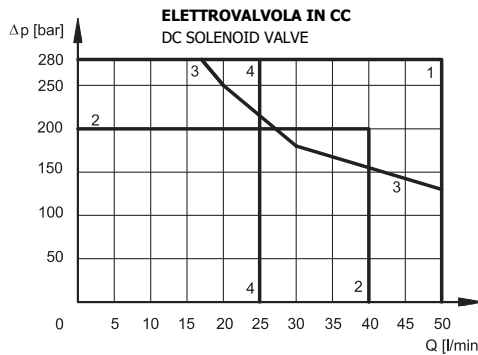

ELETTROVALVOLA IN CC
DC SOLENOID VALVE

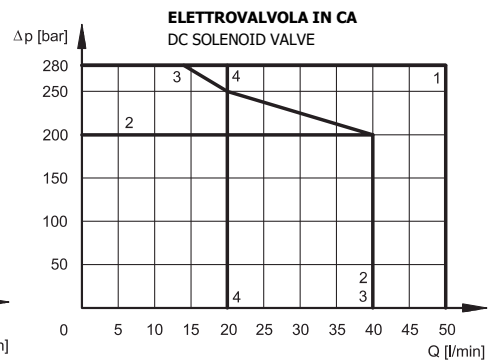

ELETTROVALVOLA IN CA
DC SOLENOID VALVE

CURSORE SPOOL	COLLEGAMENTI				FLOW DIRECTIONS	
	P→A	P→B	A→T	B→T	P→T	
	CURVE DEL DIAGRAMMA		CURVES ON GRAPH			
2-01-A, 2-01-B, 3-01	1	1	1	1	-	
2-02-A, 2-01-B, 3-01	1	1	2	2	3	
2-03-A, 2-03-B, 3-03	3	3	2	2	-	
2-04-A, 2-04-B, 3-04	4	4	4	4	5	
3-05	2	3	2	3	-	
2-05/06-A, 2-05/06-B	3	3	3	3	-	

CURSORE	SPOOL	CURVA	CURVE
3-01,	2-05/06-A/B	1	
	2/3-02-A/B	2	
	2/3-03-A/B	3	
	2/3-04-A/B	4	

CURSORE	SPOOL	CURVA	CURVE
3-01,	2-05/06-A/B	1	
	2/3-02-A/B	2	
	2/3-03-A/B	3	
	2/3-04-A/B	4	

22 Valvole e accessori modulari Cetop3

Cetop3 modular valves and accessories

Valvola di controllo di flusso CETOP3 CETOP3 modular flow control valve

Flusso controllato in uscita **U** o in entrata **E**
Flow controlled on outlet **U** or on return **E**

Porte controllate **AB, AX, BX**
Flow controlled ports **AB, AX, BX**

VCF * **

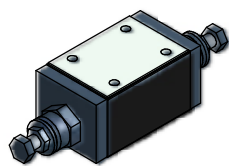
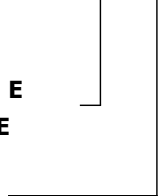

Versioni disponibili
Available version

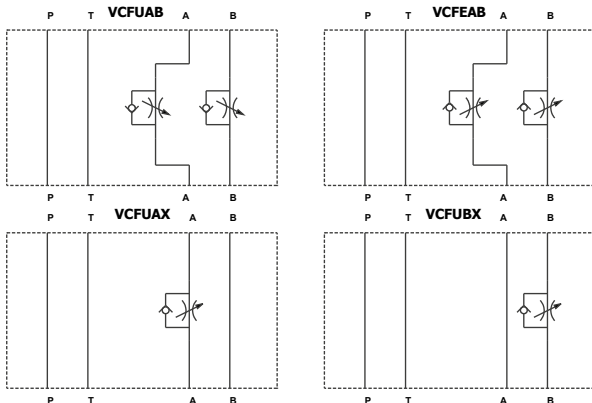

CURVE CARATTERISTICHE
(valori ottenuti con viscosità 36 cSt a 50°C)

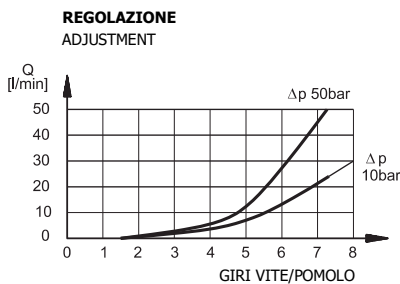

CHARACTERISTIC CURVES
(values obtained with viscosity of 36 cSt at 50°C)

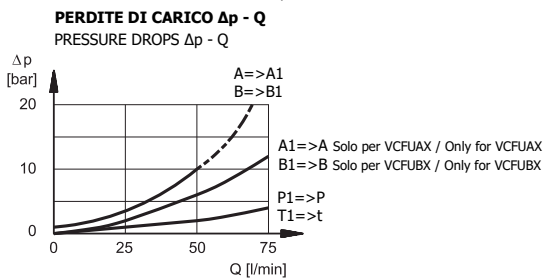

Valvola regolatrice di pressione ad azione diretta CETOP3 CETOP3 direct operated pressure relief valve

VRP ** - ***

Tipologie di regolazione:
PT, AT, BT, ATBT, ABBA

Pressure relief scheme types:
PT, AT, BT, ATBT, ABBA

Campo di regolazione: **2,3,4,5,6**
Pressure control range: **2,3,4,5,6**

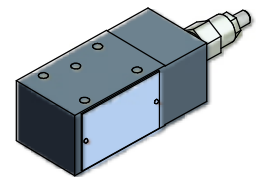
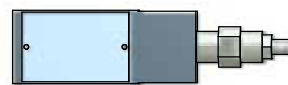
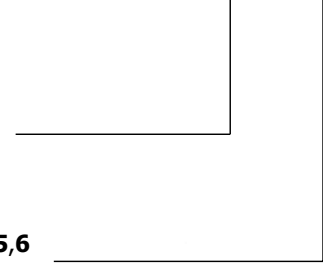

Versioni disponibili
Available version

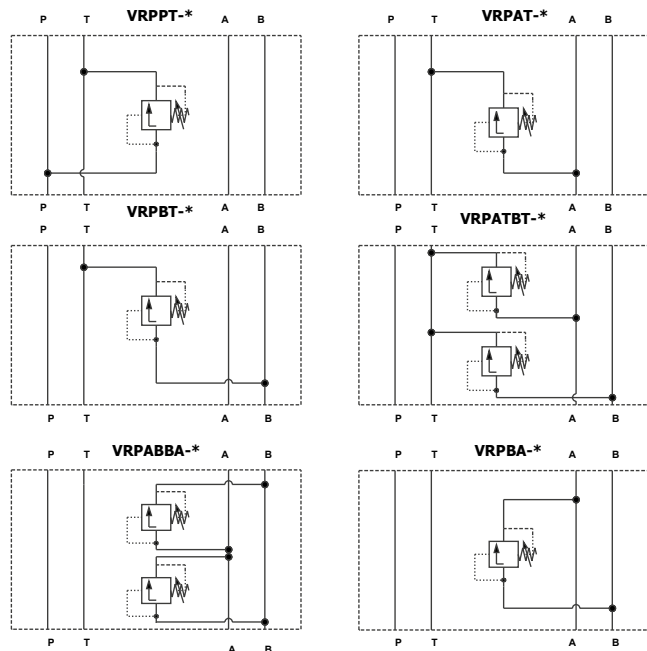

CURVE CARATTERISTICHE
(valori ottenuti con viscosità 36 cSt a 50°C)

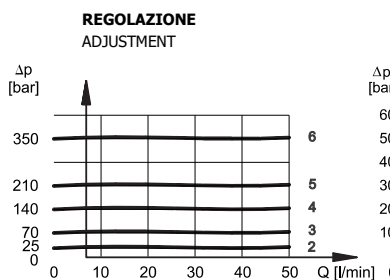

CHARACTERISTIC CURVES
(values obtained with viscosity of 36 cSt at 50°C)

PERDITE DI CARICO E PRESSIONE MINIMA REGOLATA
PRESSURE DROPS AND MINIMUM REGULATED PRESSURE

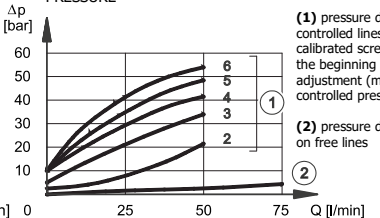

(1) condotti controllati con vite tarata ad inizio regolazione (pressione minima regolata)

(2) perdite di carico nei condotti liberi

(1) pressure drops on controlled lines with calibrated screw at the beginning of the adjustment (minimum controlled pressure)

(2) pressure drops on free lines

22 Valvole e accessori modulari Cetop3

Cetop3 modular valves and accessories

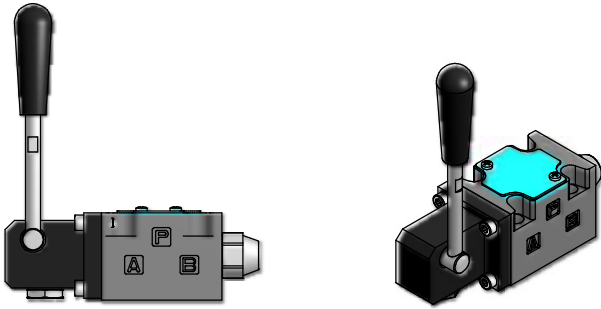

Valvola direzionale CETOP3 ad azionamento manuale
Lever operated CETOP3 directional valve

Versioni disponibili
Available version

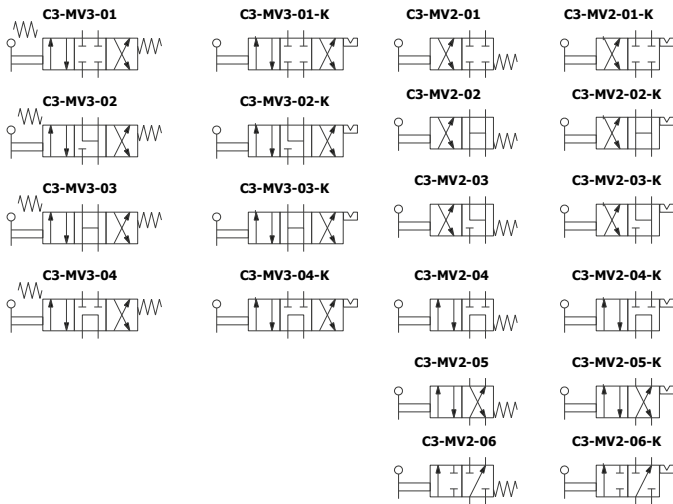

C3 - MV* - ** - *

Numero di posizioni
 Valve positions number

N° riferimento schema idraulico
 Hydraulic scheme reference n°

Ritorno a molla se ommesso, «K» con detent
 Spring return if omitted, «K» with detent

PERDITE DI CARICO Δp-Q

(valori ottenuti con viscosità 36 cSt a 50 °C)

PRESSURE DROPS Δp-Q

(values obtained with viscosity of 36 cSt at 50°C)

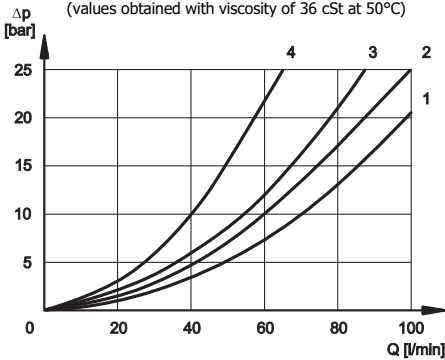

VALVOLA COMMUTATA
VALVE IN ENERGIZED POSITION

CURSORE SPOOL	COLLEGAMENTI		FLOW DIRECTIONS	
	P→A	P→B	A→T	B→T
CURVE DEL DIAGRAMMA CURVES ON GRAPH				
3-01, 2-01, 2-01-K	2	2	3	3
3-03, 2-03, 2-03-K	1	1	3	3
3-02, 2-02, 2-02-K	3	3	1	1
3-04, 2-04, 2-04-K	4	4	4	4
2-05, 2-05-K	3	3	3	3
2-06, 2-06-K	3	3		

VALVOLA IN POSIZIONE CENTRALE
VALVE IN DE-ENERGIZED POSITION

CURSORE SPOOL	COLLEGAMENTI			FLOW DIRECTIONS	
	P→B	A→T	B→T	P→T	
CURVE DEL DIAGRAMMA CURVES ON GRAPH					
3-03, 2-03, 2-03-K				2	
3-02, 2-02, 3-03-K		3	3		
3-04, 2-04, 2-04-K					3



FLUID SYSTEMS MANUFACTURING

Brands incorporated



Nexoil s.r.l.

Sede legale ed amministrativa

Headquarters

Via per Fagnano, 27 - 21052 Busto Arsizio (VA)

Tel. +39 0331 636390 Fax +39 0331 635860

C.F. e P.I. 03175670128

Unità produttiva, commerciale e tecnica

Production, Sales and Technical Dept.s

Corso Moncenisio, 18 - 10090 Rosta (TO)

Tel. +39 011 9342434 Fax +39 011 9370532

Ufficio commerciale

Sales Dept.

Via per Fagnano, 27 - 21052 Busto Arsizio (VA)

Tel. +39 0331 636390 Fax +39 0331 635860

