

# NEXOIL

FLUID SYSTEMS MANUFACTURING



## FB

ELECTRIC PUMP FOR SYSTEMS OF  
MULTIPLE LINE LUBRICATION WITH  
GREASE AND OIL

INSTALLATION, USE AND MAINTENANCE MANUAL

# CE

Edition 04/2021  
Z3321004EN

# INDEX

INTRODUCTION .....	3
DESCRIPTION AND TECHNICAL CHARACTERISTICS .....	3
ORDERING NUMBER .....	4
INSTALLATION .....	4
FB10 .....	5
FB20 .....	5
FB30 .....	6
FB60 .....	6
PUMP COMPONENTS .....	7
START UP AND FILLING OF PUMP .....	8
PUMP OPERATION (FIG 1) .....	8
PUMPING ELEMENT OPERATION (FIG 2).....	8
REDUCING NUMBER OF PUMPING ELEMENTS .....	9
REPLACING PUMPING ELEMENTS .....	9
ELECTRICAL CONNECTION .....	10
Motor.....	10
Alternate Current Power Supply.....	10
Direct Current Power Supply .....	10
Min and max electric levels.....	10
POSSIBILITY OF MALFUNCTION .....	11
WARRANTY .....	12
Canceling warranty.....	12
DECLARATION OF CONFORMITY.....	13

## INTRODUCTION

This installation, use and maintenance manual refers to the FB series electric pump for grease and oil lubrication systems  
 Keep this manual properly in order to avoid its damage.

## DESCRIPTION AND TECHNICAL CHARACTERISTICS

The pumps FB series are characterized by their robustness and reliability. They have the possibility of feeding multiple lines, up to 24, high pressure (350 bar), with individually adjustable delivery  
 Nelle seguenti tabelle sono riportate le caratteristiche tecniche delle elettropompe serie FB.

Number of ways:	from 1 to 24
Max working pressure:	350 bar
Motor power:	0,37 kW (220/440V 50/60Hz) 0.30kW (24V CC)
Tanks capacity:	10-20-30-60 kg
Delivery:	adjustable, from 0 to max. (see tab. below).
Delivery fitting:	for dia.8mm tube
MAX and MIN visual level:	standard
Minimum electric level:	standard on 10-30-60 kg. *
Maximum electric level:	optional on 10-30-60 kg. *
(* not available on 20kg).	

External transmission ratio	Internal transmission ratio	Overall transmission ratio	Motor rotation speed (rpm)	Control shaft (rpm)	Maximum flow rate for each outlet with electric motor 1500 rpm
10:1	6,6:1	66:1	1500	22,7	0 ÷ 3,40
7,5:1	6,6:1	49.5:1	1500	30.3	0 ÷ 4,50
5:1	6,6:1	33:1	1500	45.4	0 ÷ 6,80

Maximum outlet flow rate in relation to motor shaft speed

$$Q_{\max} = n/R \times 0,15$$

Q = Flow Rate in cm<sup>3</sup>/min  
 R = Overall transmission ratio  
 n = Motor shaft rpm

## ORDERING NUMBER

<b>FB</b>	<b>20<sup>(1)</sup></b>	<b>/</b>	<b>16<sup>(2)</sup></b>	<b>/</b>	<b>10<sup>(3)</sup></b>	<b>C<sup>(4)</sup></b>	<b>/380 V<sup>(5)</sup> 50 Hz</b>
-----------	-------------------------	----------	-------------------------	----------	-------------------------	------------------------	-----------------------------------

- 1) TANK CAPACITY:           **10-20-30-60kg**
- 2) NUMBER OF OUTLETS: **(from 1 to 24)**
- 3) EXTERNAL TRANSMISSION RATIO (see tab pag.3)
- 4) MAX ELECTRIC LEVEL: **C = CON, S = SENZA**
- 5) POWER SUPPLY: **220/440 50/60Hz - 24CC**

## INSTALLATION

The installation and use of the FB series electric pump must be entrusted to qualified personnel with basic knowledge of hydraulics and electricity. Check the integrity of the device and accessories, verifying that they have not been damaged during shipping.

In case of damage to the unit, do not operate.

In the event of a complaint, immediately contact the sales office of NEXOIL srl. Any damage to the power cables and the electric motor can lead to contact with high voltage live parts and therefore the danger of death.

The pump may only be repaired by specialized personnel.

In order to prevent electrocution hazards due to direct or indirect contact with live parts, the power supply line must be adequately protected by a special differential magnetothermal switch with tripping threshold based on the characteristics of the electric motor, and max. of 1 second.

It is forbidden to use the pump in a particularly aggressive or explosive/flammable environment unless expressly made with ATEX components.

For floor mounting, 4 fixing holes are provided as indicated in the paragraph "FIXING AND DIMENSIONS"

It is necessary to provide adequate spaces to avoid the possibility of collisions and to allow maintenance operations.

For the electrical connections, refer to the "ELECTRICAL CONNECTIONS" paragraph.

## FIXING AND DIMENSIONS

For fixing to the floor there are 4 holes Dia. 11mm. (420x360mm).

### FB10

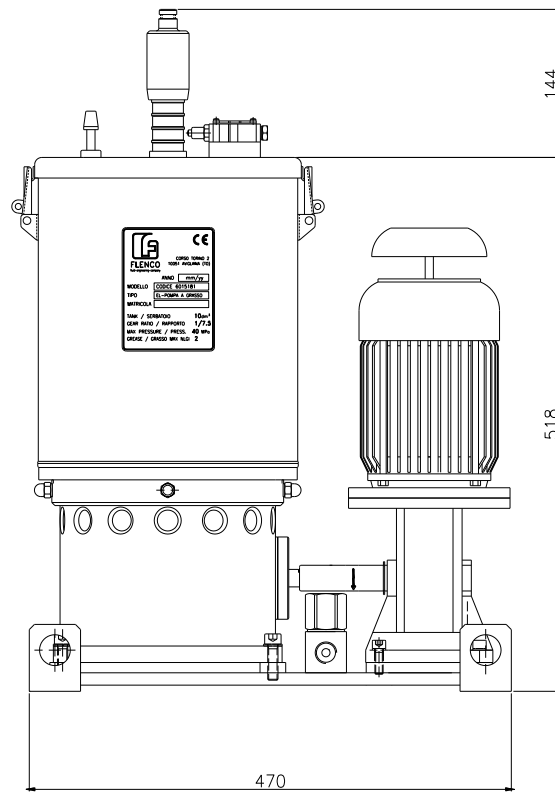

### FB20

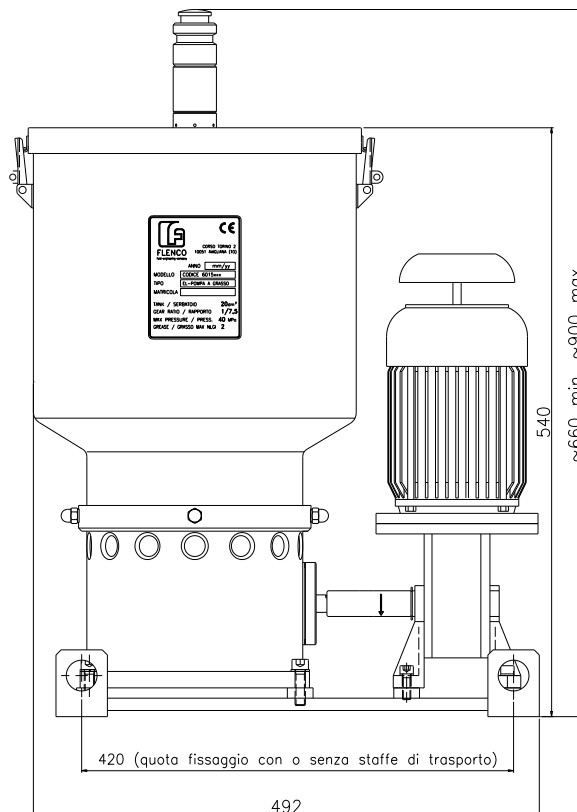

## FB30

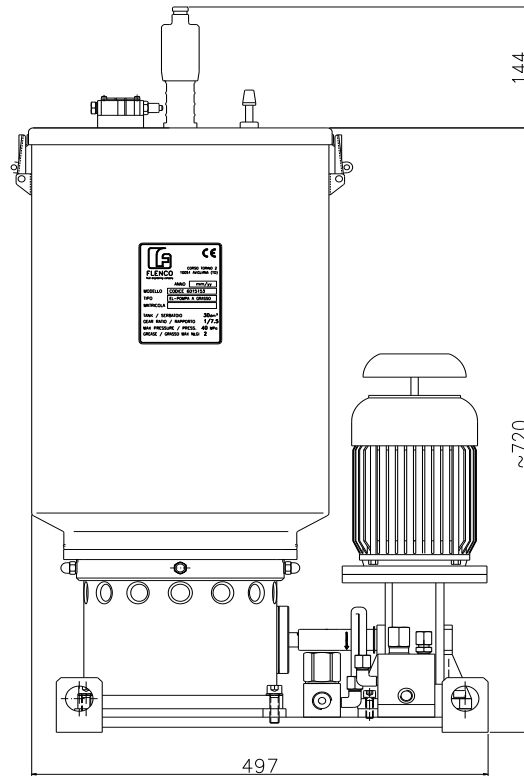

## FB60

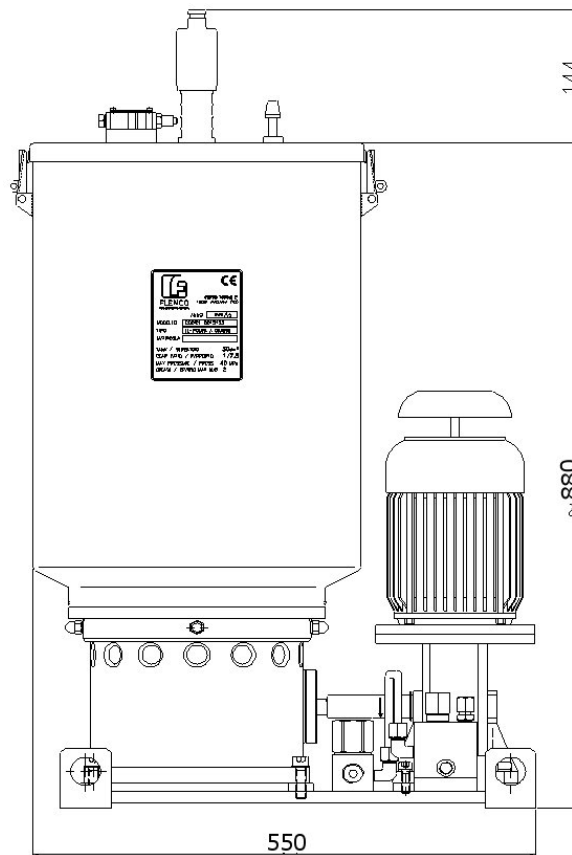

## PUMP COMPONENTS

As shown in Fig. 1, the pump is made up of:

- |  |   |
|--|---|
| 1. Pump body containing all mechanisms | 8. Cover                                  |
| 2. Caps to close unused outlets        | 9. Air valve                              |
| 3. Control shaft with worm screw       | 10. Micro gauge for min. level (OPTIONAL) |
| 4. Pumping elements                    | 11. Pump shaft                            |
| 5. Mixer                               | 12. Pumping element control rings         |
| 6. Pressing piston                     | 13. Eccentric bush                        |
| 7. Tank                                | 14. Helical wheel                         |

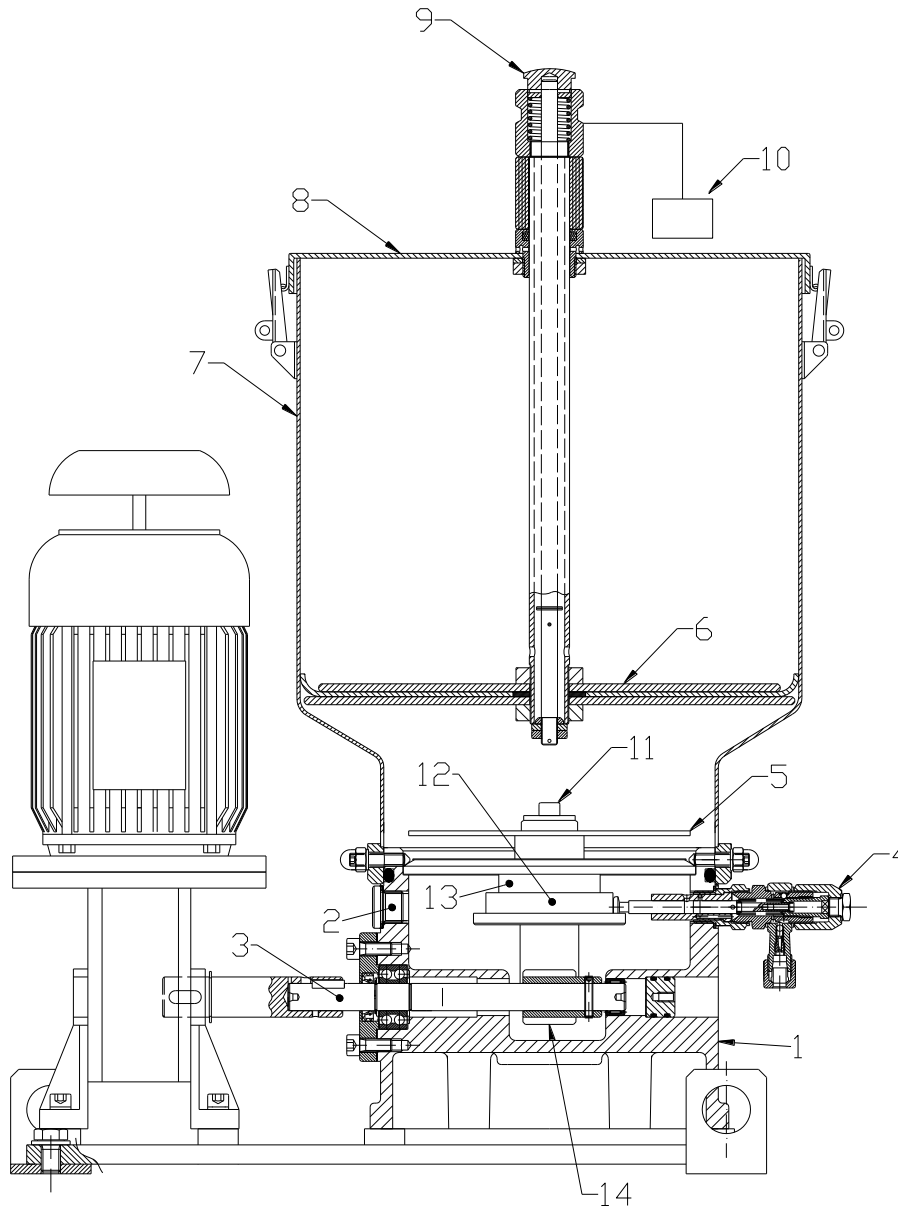

**Figura 1**

**START UP AND FILLING OF PUMP**

The FB Pump is supplied with the pumping elements already primed and the sufficient quantity of grease used for priming and testing.

After installation, proceed with filling the tank using the loading filter, if present. This prevents the intrusion of dirt and the possibility of the presence of air in the suction area of the pumping elements which would cause them to be unprimed.

In the event that one or more pumping elements were disengaged or even for restarting the pump after maintenance which involved the complete removal of the grease, it is advisable to start and prime the pumping elements with oil (possibly of the SAE 90 type or SAE 140)

Therefore, pour into the tank just enough oil to reach the mixer. Then run the pump until the oil comes out of the delivery connections of the pumping elements without the presence of air bubbles.

At this point the tank can be filled, through the loading filter, with the grease required for operation.

**PUMP OPERATION (FIG 1)**

The pump is operated by means of the external part of the control shaft 3 which, through the worm screw/helical wheel reduction 14, transmits motion to the pump shaft 11 and then to the eccentric bush 13 and the mixer 5.

The control rings 12 are mounted idle on the eccentric bush 13 and the pumping pistons are hooked positively to them.

The mixer 5 forces the lubricants to reach the suction chamber.

The cover can be slipped off by operating the air valve 9 which puts the inside of the tank in communication with the atmosphere.

**PUMPING ELEMENT OPERATION (FIG 2)**

The pumping element 1, whose stroke is determined by the eccentricity of the bush 12 in Fig. 1, is shown in Fig. 2 during the suction phase.

In this position the dosing piston 2 closes the delivery hole.

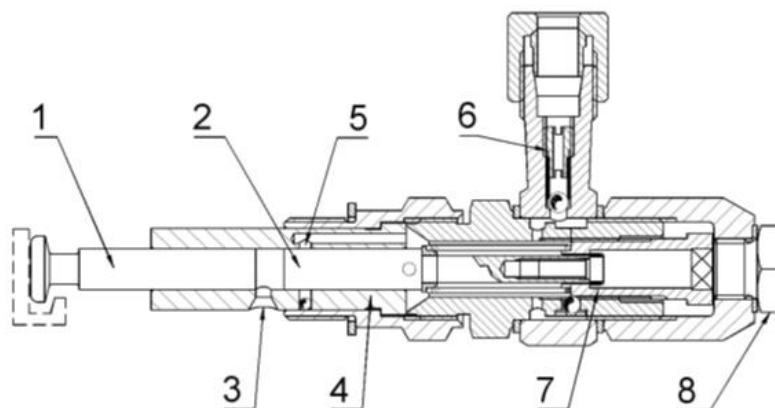

Fig. 2



When the pumping piston 1 starts the delivery stroke, it obstructs the hole 3. The lubricant trapped in the bushing 4, moves the dosing piston 2 which uncovers the whole 3.

Therefore, the lubricant can be directed to the outlet through the internal ducts. The check valve 6 prevents reflow during suction.

The position of the bushing 7 established by the knob 8 determines the flow rate. In fact, the further advanced the end of the dosing piston 2 is, the more it will reduce the usable displacement volume.

The flow rate of the pumping element will therefore decrease by rotating the knob 8 clockwise and will increase by rotating counterclockwise.

### REDUCING NUMBER OF PUMPING ELEMENTS

You can reduce the number of pumping elements by removing them as shown in Fig. 3.

The holes that remain open must then be closed with M20x1.5 stoppers.

### REPLACING PUMPING ELEMENTS

To remove a pumping element, start unscrewing it from the pump body. When the threading is disengaged, tilt the element downward and slip it out. Make sure the piston A (Fig.3) does not fall inside the pump.

When reassembling the pumping element it is indispensable to make sure that the piston A is hooked to the camshaft B.

Note: Eliminating the grease during the removal and insertion phase facilitates the operations and allows you to visually verify that the coupling has actually taken place.



Figura 3

**ELECTRICAL CONNECTION**

**Motor**

For the electric motor, equipped with rain cover, use the following connection diagrams:

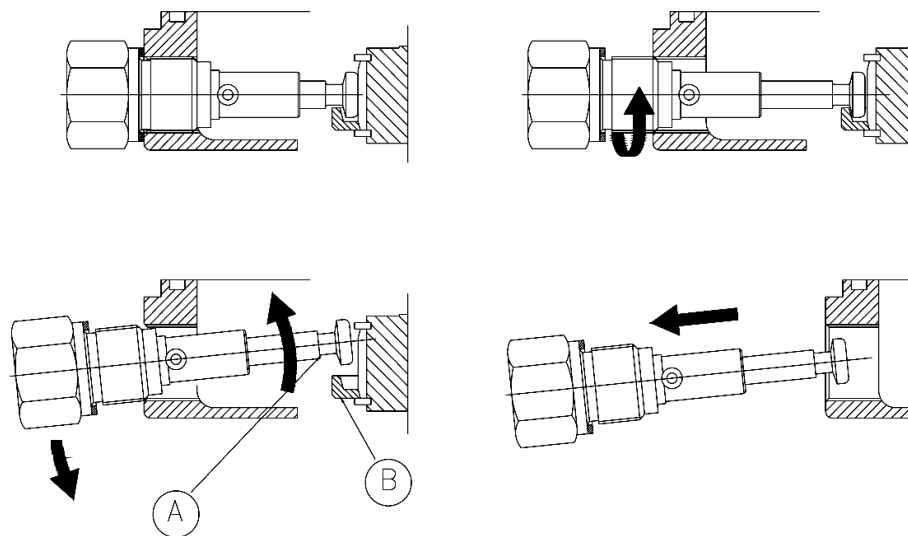
**Alternate Current Power Supply**

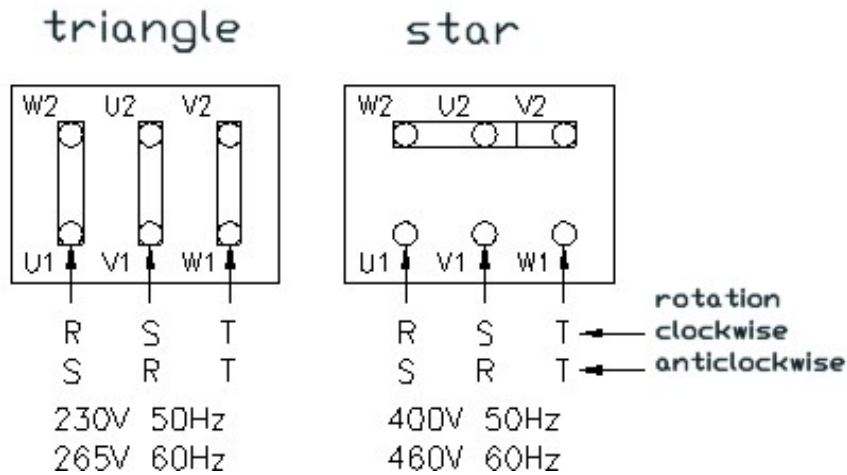

**Direct Current Power Supply**

Connect the two poles to the motor terminal board checking that the voltage value corresponds to the motor characteristics.

**ATTENTION:**

Always check the correct direction of rotation of the drive shaft (3 fig.1). To do this, refer to the adhesive arrow applied to it. If necessary, correct the electrical connection of the motor.

**Min and max electric levels**

For the MIN and MAX electrical levels, which can be NO or NC depending on the connection, use the following connection diagram:

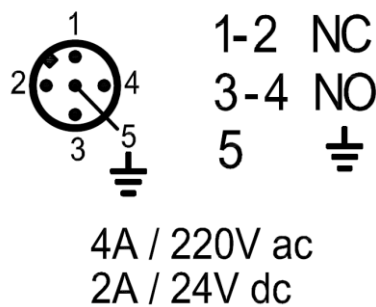

## POSSIBILITY OF MALFUNCTION

### CAUSES AND REMEDIES

<b>DEFECT:</b>	NO Delivery from Pumping Elements
<b>CAUSES:</b>	The pumping elements have not been purged adequately or the dosing piston 2 is blocked.
<b>CONTROLS:</b>	Remove the adjustment knob 8 and place a screwdriver on the head of the dosing piston 2. While the pump is operating, when pressing on the piston you should feel it move.
<b>ELIMINATION:</b>	Wait until the grease stops leaking without blowholes. If this is not sufficient, disassemble the pumping element, clean it and make sure all the parts can slide. Reassemble it as shown in fig.2.
<b>DEFECT:</b>	Delivey insufficient and irregular..
<b>CAUSES:</b>	The check valve 6 does not close perfectly (the defect is found mainly with high counterpressures) or the dosing piston 2 is temporarily blocked.
<b>CONTROLS:</b>	Disconnect the pipe and install a 0-600 bar gauge with a maximum pressure valve on the outlet of the pumping element. Regulate the maximum valve to 350 bar. During operation between two successive pulses, the pressure must not drop below 200 bar. If necessary, perform the control described under point "NO Delivery from Pumping Elements".
<b>ELIMINATION:</b>	Replace the valve-carrying union or install a supplementary check valve at the outlet of the pumping element. MAKE to disassemble and clean.
<b>DEFECT:</b>	Decreased performance
<b>CAUSES:</b>	Parts 1-2-4 are worn out (fig. 2)
<b>CONTROLS:</b>	Disassemble the pumping unit and make sure there is no play in the couplings.
<b>ELIMINATION:</b>	Replace parts 1-2-4 or the complete pumping element.

## **WARRANTY**

For any defects of construction and material Nexoil guarantees its products for a maximum of 12 months from the date of delivery.

The warranty covers up to a maximum of 18 months in the case in which the installation is performed over the 6 months following the date of delivery.

Parts subject to normal wear and tear are not covered by the warranty.

In case of failure, communicate to Nexoil: defect, product code, serial number (if any), delivery date, installation date, other that may be useful for management reporting.

The Nexoil will provide telephone support or on-site depending on the situation or communicate the return authorization number (RNC) for returning the part. In the latter case the Nexoil reserves the right to choose between repair and replacement.

If the warranty is still valid, the particular will, free of charge, repaired or replaced.

If the products are not found defective, the Nexoil will decide whether to charge the customer for the costs incurred.

Are to be considered excluded from the warranty damage, injury or expense arising from any defect of the product.

The conditions of validity of the product warranty Nexoil are implicitly accepted at the time of purchase of the product.

### **Canceling warranty**

The warranty is considered to be annulled in the following cases:

- The product is damage by improper use, incorrect installation and use other than that intended.
- The product underwent tampering and/or modifications without written permission of Nexoil srl.

## DECLARATION OF CONFORMITY



### DICHIARAZIONE DEL FABBRICANTE

#### DECLARATION BY THE MANUFACTURER

*Ai sensi dell'allegato II. B – della Direttiva 2006/42/CE sulle Macchine  
(Macchine destinate all'incorporazione in altre macchine o linee)*

*In accordance to the annex II. B – Directive 2006/42/CE – Machinery (Machinery for incorporation into other machines or lines)*

**NEXOIL s.r.l.**

Dichiara sotto la propria responsabilità che il prodotto denominato:  
*Declares under its own responsibility that the product named:*

Descrizione:  
*Description:* FB – Pompa Elettrica a linee multiple

Codice articolo:  
*Item Number:* 6015xxx

Matricola:  
*Serial Number:* xxxxxxxx yy / zz

È conforme alle disposizioni legislative Nazionali che traspongono le seguenti Direttive CE:  
*is in conformity with Nation laws that transposing the following EC Directives:*

- Direttiva Macchine 2006/42/CE.
- Direttiva Bassa Tensione 2006/95/CE.
- Direttiva Compatibilità Elettromagnetica 2004/108/CE

#### AVVERTENZA IMPORTANTE!

È vietato mettere in servizio il prodotto oggetto della presente dichiarazione, prima del completamento e/o incorporamento, in totale conformità alle disposizione della Direttiva Macchine 2006/42/CE.

#### IMPORTANT WARNING!

*It is forbidden to operate the product object of this declaration before to the completion and/or building in in full compliance with the Machinery Directive 2006/42/EC.*

Avigliana, il 09/03/2023

NEXOIL s.r.l.  
Sede Legale e Amministrativa:  
Via per Estimino n. 27  
21082 GUSTO ARSIZIO (VA)  
C.F. e Part. IVA: 03175670126



**Nexoil s.r.l.**

**Sede legale ed amministrativa**  
Via per Fagnano, 27 21052 Busto Arsizio (VA)  
Tel. +39 0331 636390 - Fax +39 0331 622684

**Ufficio commerciale e tecnico**  
Corso Torino, 2 - 10051 Avigliana (TO)  
Tel. +39 011 9342434 - Fax +39 011 9370532

**Ufficio commerciale**  
Via S. Maria Rossa, 8 - 20132 Milano  
Tel. +39 02 26306266 - Fax +39 02 26306274

Registro delle imprese di Varese, C.F. e P.I. 03175670128 - N° REA: VA 329250 - Cap. Soc. 100.000,00 €

NOTE





Nexoil s.r.l.

Sede legale ed amministrativa

*Headquarters*

Via per Fagnano, 27 - 21052 Busto Arsizio (VA)

Tel. +39 0331 636390 Fax +39 0331 622684

Unità produttiva, commerciale e tecnica

*Production, Sales and Technical Dept.s*

Corso Moncenisio, 18 - 10090 Rosta (TO)

Tel. +39 011 9342434 Fax +39 011 9370532

[www.nexoil.it](http://www.nexoil.it)

This manual is the property of NEXOIL srl.

The NEXOIL reserves the right to make changes, at any time and without prior notice, for technical and commercial reasons.

Reproduction of any part of this manual is forbidden by law without the written permission of the NEXOIL srl srl

Copyright © 2021 by NEXOIL srl.